

Installation and Service Manual
High-efficiency wall-hung condensing gas boiler

224 Combi 2 - 228 Combi 2
224 Combi 2 LPG

Исходные данные, относящиеся к данному документу, см. в таблице. Ссылки на другие документы, которые могут понадобиться при установке, сервисном обслуживании и ремонте, см. в разделе «Ссылки на документы» в главе 1.

Dear Customer,

Thank you very much for buying this appliance.

Please read through the manual carefully before using the product, and keep it in a safe place for later reference. In order to ensure continued safe and efficient operation we recommend that the product is serviced regularly. Our service and customer service organisation can assist with this.

We hope you enjoy years of problem-free operation with the product.

Contents

1	Safety	6
1.1	Benchmark	6
1.1.1	Building regulations and the benchmark commissioning checklist	6
1.1.2	The benchmark scheme	6
1.1.3	Installer notification guidelines	7
1.2	General safety instructions	8
1.3	Recommendations	8
1.4	Specific safety instructions	9
1.4.1	Handling	9
1.5	Liabilities	10
1.5.1	Manufacturer's liability	10
1.5.2	Installer's liability	10
1.5.3	User's liability	10
2	About this manual	11
2.1	General	11
2.2	Additional documentation	11
2.3	Symbols used	11
2.3.1	Symbols used in the manual	11
2.4	Abbreviations/glossary	11
3	Technical specifications	12
3.1	Homologations	12
3.1.1	Safety, performance & quality	12
3.1.2	Certifications	12
3.1.3	Gas category	12
3.1.4	Standards	12
3.2	Technical data	13
3.2.1	Technical information	13
3.2.2	Features of the temperature sensors	16
3.3	Dimensions and connections	16
3.4	Electrical diagram	18
4	Description of the product	19
4.1	General description	19
4.2	Operating principle	19
4.2.1	Air-gas adjustment	19
4.2.2	Combustion	19
4.2.3	Heating and domestic hot water production	19
4.2.4	Schematic diagram	20
4.3	MAIN COMPONENTS	20
4.4	Control panel description	21
4.4.1	Description of the control panel	21
4.5	Contents of the package	21
4.6	Accessories & options	21
5	Before installation	22
5.1	Installation standards and rules	22
5.2	Installation requirements	22
5.2.1	Gas supply	22
5.2.2	Electrical supply	22
5.2.3	Hard water area	23
5.2.4	Bypass	23
5.2.5	System control	23
5.2.6	Treatment of water circulating systems	23
5.2.7	Showers	24
5.2.8	Expansion vessel (CH only)	24
5.2.9	Safety pressure relief valve	24
5.3	Flow rate/head at the plate characteristics	25

5.4	Choice of the location	26
5.4.1	Location of the boiler	26
5.4.2	Bath and shower rooms	26
5.4.3	Ventilation	27
5.4.4	Condensate drain	27
5.4.5	Clearances	29
5.4.6	Flue/chimney location	29
5.4.7	Horizontal flue/chimney systems.	31
5.4.8	Flue/chimney trim	32
5.4.9	Terminal guard	32
5.4.10	Flue/chimney deflector	32
5.4.11	Flue/chimney accessories	32
5.4.12	Data plate and boiler service level	33
5.5	Transport	33
5.6	Unpacking and initial preparation	34
5.6.1	Unpacking	34
5.6.2	Initial preparation	35
5.7	Connecting diagrams	35
5.7.1	Filling information	35
5.7.2	Domestic hot water circuit	36
6	Installation	37
6.1	General	37
6.2	Assembly	37
6.2.1	Fitting the pressure relief discharge pipe.	37
6.2.2	Connecting the condensate drain	38
6.3	Air supply/flue gas connection	38
6.3.1	Connecting the flue/chimney	38
6.4	Electrical connections	39
6.4.1	Accessing the electrical connections	40
6.4.2	Connecting the room thermostat	40
6.4.3	Service connection (SERVICE)	41
6.4.4	Connecting on wall outdoor sensor.	41
6.4.5	Connecting the outside sensor.	41
6.4.6	Identifying label	41
6.5	Filling the installation	42
6.5.1	Flushing the system	42
6.5.2	Fill the installation	42
6.5.3	Filling the condensate trap.	42
6.6	Draining the installation	42
7	Commissioning	43
7.1	General	43
7.2	Checklist before commissioning	43
7.3	Commissioning procedure	43
7.4	Gas settings	44
7.4.1	Check the operational (working gas inlet pressure and gas rate).	44
7.4.2	Combustion parameters.	44
7.4.3	Service settings	46
7.4.4	Calibrating the gas valve	46
7.5	Final instructions	49
7.5.1	Handover	49
8	Operation	50
8.1	Use of the control panel	50
8.1.1	Browsing the menus	50
8.1.2	Running the automatic detection function	50
8.1.3	Information menu display.	50
8.1.4	Counter menu display.	50

8.2	Start-up	51
8.2.1	Procedure for first start-up	51
8.2.2	Changing the heating flow temperature	51
8.2.3	Changing the domestic hot water (DHW) temperature	51
8.3	Shutdown	52
8.3.1	Switching off the heating and domestic hot water (DHW)	52
8.4	Degassing function	52
8.5	Frost protection	52
9	Settings	53
9.1	Accessing the settings	53
9.2	List of parameters	53
9.2.1	Resetting factory settings	57
9.3	Setting the parameters	57
9.3.1	Setting the heating curve	57
9.4	Reading out measured values	58
9.4.1	Statuses and sub-statuses	59
9.5	Reading meters	61
10	Maintenance	62
10.1	General	62
10.2	Maintenance message	63
10.2.1	Service notification	63
10.2.2	Resetting the displayed maintenance message	64
10.2.3	Resetting the upcoming maintenance message	64
10.3	Periodic check and maintenance procedure	65
10.3.1	Checking the water pressure	66
10.3.2	Checking the expansion vessel	66
10.3.3	Checking the flue gas discharge and the air supply	66
10.3.4	Checking the combustion	66
10.3.5	Checking the automatic air vent	66
10.3.6	Cleaning the siphon	66
10.3.7	Checking the burner and cleaning the heat exchanger	67
10.3.8	Electrode distances	68
10.3.9	Water unit	68
10.3.10	Removing limescale	69
10.4	Specific maintenance operations	70
10.4.1	Detection/ignition electrode replacement	70
10.4.2	Dismantling the water-water exchanger	70
10.4.3	Replacing the 3-way valve	70
10.4.4	Pump motor replacement	71
10.4.5	Replacing the expansion vessel	71
10.4.6	Replacing the PCB	71
11	Troubleshooting	72
11.1	Temporary and permanent faults	72
11.2	Error codes	72
12	Decommissioning	77
12.1	Disassembly	77
12.2	Recommissioning	77
13	Disposal	78
13.1	Disposal and recycling	78

1 Safety

1.1 Benchmark

1.1.1 Building Regulations and the Benchmark Commissioning Checklist

Building Regulations (England & Wales) require notification of the installation of a heating appliance to the relevant Local Authority Building Control Department. This can be achieved via a Competent Persons Self Certification Scheme as an option to notifying the Local Authority directly.

The Health & Safety Executive operates the 'Gas Safe Register', a self-certification scheme for gas heating appliances.

This company is a member of the Benchmark initiative and fully supports the aims of the programme. Its aim is to improve the standards of installation and commissioning of central heating systems in the UK and to encourage the regular servicing of all central heating systems to ensure safety and efficiency.

Building Regulations require that installations should comply with manufacturer's instructions. It is therefore important that the commissioning checklist is completed by the installer. The relevant section of Building Regulations only relates to dwellings. Therefore the checklist only applies if the appliance is being installed in a dwelling or some related structure.

The flowchart opposite gives guidance for installers on the process necessary to ensure compliance with Building Regulations.

1.1.2 The Benchmark Scheme

Benchmark places responsibilities on both manufacturers and installers. The purpose is to ensure that customers are provided with the correct equipment for their needs, that it is installed, commissioned and serviced in accordance with the manufacturer's instructions by competent persons and that it meets the requirements of the appropriate Building Regulations. The Benchmark Checklist can be used to demonstrate compliance with Building Regulations and should be provided to the customer for future reference.

Installers are required to carry out installation, commissioning and servicing work in accordance with the Benchmark Code of Practice which is available from the Heating and Hotwater Industry Council who manage and promote the Scheme. Visit www.centralheating.co.uk for more information.

Fig.1 Benchmark



1.1.3 Installer Notification Guidelines

Fig.2 Installer Notification Guidelines

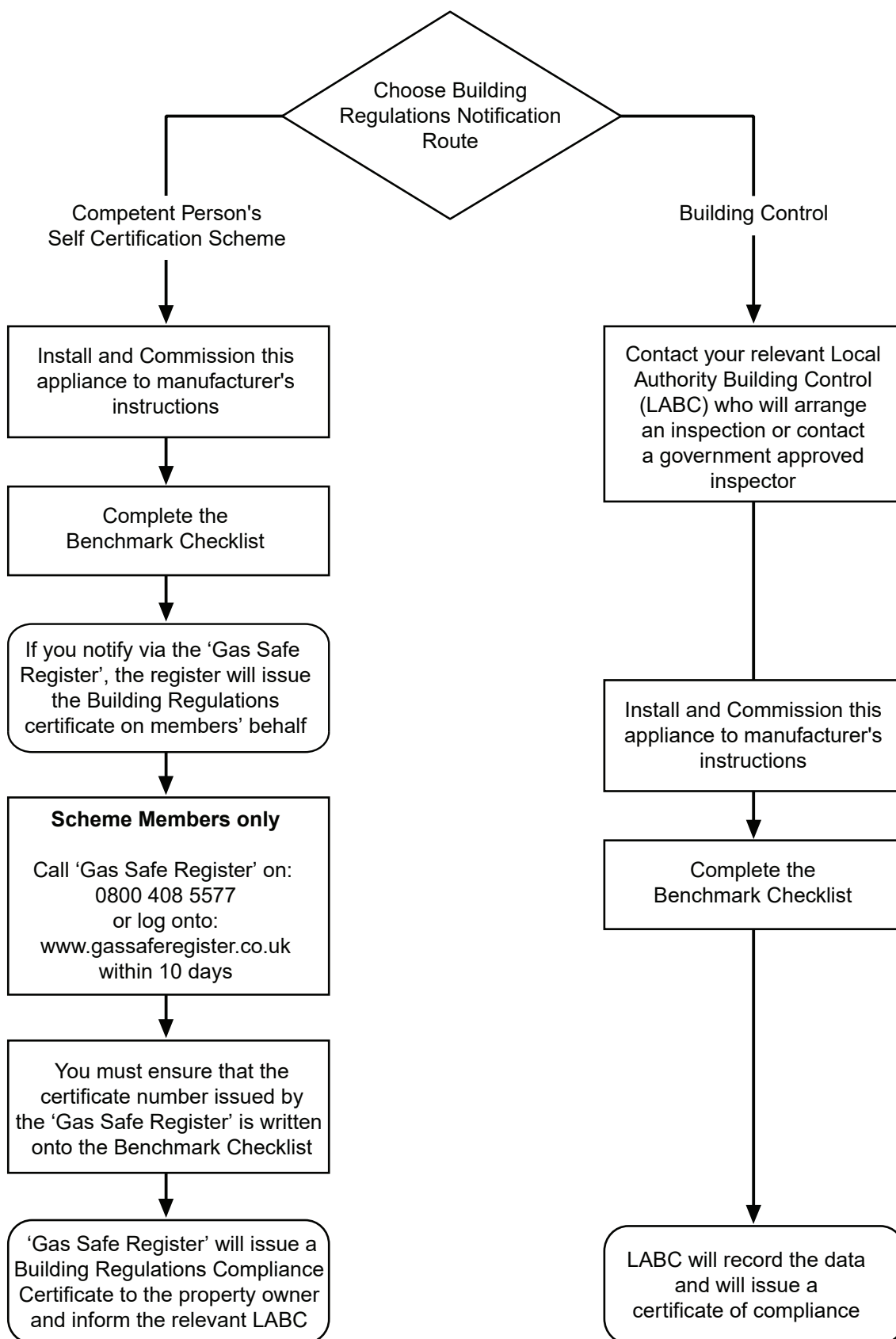

AD-3000696-01

1.2 General safety instructions



Danger

This boiler can be used by children aged 8 years and above and by persons with reduced physical, sensory or mental capabilities or lack of experience and knowledge when they have been given supervision or instruction concerning the safe use of the device and understand the resulting risks. Children must not be allowed to play with the appliance. Cleaning and user maintenance must not be carried out by children without supervision.



Danger

If you smell gas:

1. Do not use a naked flame, do not smoke, do not operate electrical contacts or switches (doorbell, light, motor, lift, etc.).
2. Shut off gas supply.
3. Open the windows.
4. Trace possible leaks and seal them immediately.
5. If the gas leak is before the gas meter, contact the supplier
6. Telephone the National Gas Emergency Service on:- 0800 111 999.



Danger

If you smell flue gases:

1. Switch off the boiler.
2. Open the windows.
3. Trace possible leaks and seal them immediately.



Warning

Do not touch the flue gas pipes. Depending on the boiler settings, the temperature of the flue gas pipes may exceed 60°C.



Warning

Do not touch the radiators for long periods. Depending on the boiler settings, the temperature of the radiators may exceed 60°C.



Warning

Take precautions with the domestic hot water. Depending on the boiler settings, the domestic hot water temperature may exceed 65°C.



Danger

Before any work, switch off the mains supply to the boiler.



Caution

After maintenance or repair work, check the entire heating installation to ensure that there are no leaks.

1.3 Recommendations



Warning

Installation and maintenance of the boiler must be carried out by a qualified installer in accordance with local and national regulations.



Warning

If the mains lead is damaged, it must be replaced by the original manufacturer, the manufacturer's dealer or another suitably skilled person to prevent hazardous situations from arising.



Warning

Always disconnect the mains supply and close the main gas tap when working on the boiler.

**Caution**

Make sure the boiler can be reached at all times. The boiler must be installed in a frost-free area.

In the case of a fixed connection to the power cord, you must always install a main double pole switch with an opening gap of at least 3 mm (EN 60335-1).

Drain the boiler and central heating system if you are not going to use your home for a long time and there is a chance of frost. The frost protection does not work if the boiler is out of operation.

The boiler protection only protects the boiler, not the system. Check the water pressure in the system regularly. If the water pressure is lower than 0.8 bar, the system must be topped up (recommended water pressure between 1 and 2 bar).

**Important**

Keep this document near to the boiler.

**Important**

Casing panels may only be removed for maintenance and servicing purposes. Refit all panels when maintenance work and servicing are complete.

**Note**

Instruction and warning labels must never be removed or covered and must be clearly legible throughout the entire service life of the boiler. Replace damaged or illegible instruction and warning labels immediately.

**Note**

The boiler must not be modified in any way.

1.4 Specific safety instructions

1.4.1 Handling

General

The following advice should be adhered to, from when first handling the boiler to the final stages of installation, and also during maintenance. Most injuries as a result of inappropriate handling and lifting are to the back, but all other parts of the body are vulnerable, particularly shoulders, arms and hands. Health & Safety is the responsibility of EVERYONE.

There is no "safe" limit for one man - each person has different capabilities. The boiler should be handled and lifted by TWO PEOPLE.

Do not handle or lift unless you feel physically able.

Wear appropriate Personal Protection Equipment e.g. protective gloves, safety footwear etc.

Preparation

Co-ordinate movements - know where, and when, you are both going.

Minimise the number of times needed to move the boiler - plan ahead.

Always ensure when handling or lifting the route is clear and unobstructed. If possible avoid steps, wet or slippery surfaces, unlit areas etc. and take special care on ladders/into lofts.

Technique

When handling or lifting always use safe techniques - keep your back straight, bend your knees. Don't twist - move your feet, avoid bending forwards and sideways and keep the load as close to your body as possible.

Where possible transport the boiler using a sack truck or other suitable trolley.

Always grip the boiler firmly, and before lifting feel where the weight is concentrated to establish the centre of gravity, repositioning yourself as necessary. See the "Installation" section of these instructions for recommended lift points.

Remember

The circumstances of each installation are different. Always assess the risks associated with handling and lifting according to the individual conditions.

If at any time when installing the boiler you feel that you may have injured yourself STOP !! DO NOT "work through" the pain - you may cause further injury.

IF IN ANY DOUBT DO NO HANDLE OR LIFT THE BOILER — OBTAIN ADVICE OR ASSISTANCE BEFORE PROCEEDING !

1.5 Liabilities

1.5.1 Manufacturers liability

Our products are manufactured in compliance with the requirements of the various Directives applicable. They are therefore delivered with the **CE** marking and any documents necessary. In the interests of the quality of our products, we strive constantly to improve them. We therefore reserve the right to modify the specifications given in this document.

Our liability as manufacturer may not be invoked in the following cases:

- Failure to abide by the instructions on installing the appliance.
- Failure to abide by the instructions on using the appliance.
- Faulty or insufficient maintenance of the appliance.

1.5.2 Installers liability

The installer is responsible for the installation and initial commissioning of the appliance. The installer must observe the following instructions:

- Read and follow the instructions given in the manuals provided with the appliance.
- Install the appliance in compliance with prevailing legislation and standards.
- Carry out initial commissioning and any checks necessary.
- Explain the installation to the user.
- If maintenance is necessary, warn the user of the obligation to check the appliance and keep it in good working order.
- Give all the instruction manuals to the user.

1.5.3 Users liability

To guarantee optimum operation of the system, you must abide by the following instructions:

- Read and follow the instructions given in the manuals provided with the appliance.
- Call on a qualified professional to carry out installation and initial commissioning.
- Get your installer to explain your installation to you.
- Have the required inspections and maintenance carried out by a qualified installer.
- Keep the instruction manuals in good condition close to the appliance.

2 About this manual

2.1 General

This manual is intended for installers of Baxi Combi 2 boilers

2.2 Additional documentation

These Installation & Service Instructions must be read in conjunction with the Flue Accessories Fitting Guide supplied in the Literature Pack.

Various timers, external controls, etc. are available as optional extras. Full details are contained in the relevant sales literature.

2.3 Symbols used

2.3.1 Symbols used in the manual

This manual uses various danger levels to draw attention to special instructions. We do this to improve user safety, to prevent problems and to guarantee correct operation of the appliance.



Danger

Risk of dangerous situations that may result in serious personal injury.



Danger of electric shock

Risk of electric shock.



Warning

Risk of dangerous situations that may result in minor personal injury.



Caution

Risk of material damage.



Important

Please note: important information.



See

Reference to other manuals or pages in this manual.

2.4 Abbreviations/Glossary

BS	British Standard
CH	Central heating
DHW	Domestic hot water
GB	Great Britain
HHIC	Heating and Hotwater Industry Council
Hi	Lower heating value (LHV)
Hs	Higher heating value (HHV)
IE	Ireland
PCU	PCB for managing burner operation
Pn	Nominal output
Pnc	Condensing output
SU	Safety PCB

3 Technical specifications

3.1 Homologations

3.1.1 Safety, Performance & Quality

This boiler has been assessed by an appropriate Notified Body and shown to meet the requirements of all Directives and Regulations as applicable. These Directives and Regulations lay down requirements for the safety and efficiency of the appliance, together with its design, construction and use of materials. They also require the production process to be covered by an approved and monitored system of quality assurance.

3.1.2 Certifications

Tab.1 Certifications

CE certificate number	0085CU0338
NOx class	6
Boiler type	C ₁₃ , C ₃₃

3.1.3 Gas category

Tab.2 Gas category, type and supply pressure

Gas category	Gas type	Supply pressure (mbar)
I _{2H}	G20 (H natural gas)	20
II _{2H3P}	L.P.G	37



Important

This appliance is suitable for G20 gas containing up to 20% hydrogen (H₂). Due to variations in the percentage of H₂, the percentage of O₂ may vary over time. (For example: 20% of H₂ in the gas may lead to a 1.5% increase of O₂ in the flue gases) The gas valve may need to be adjusted more accurately. This must be adjusted using standard O₂ values for the gas used.

3.1.4 Standards

Codes of Practice — refer to the most recent version

Tab.3 In GB the following Codes of Practice apply:

Standard	Scope
BS 6891	Gas Installation.
BS 5546	Installation of hot water supplies for domestic purposes.
BS EN 12828	Heating systems in buildings.
BS EN 12831	Heating systems in buildings — Calculation of load.
BS EN 14336	Installation & commissioning of water based heating systems.
BS 6798	Installation of gas fired hot water boilers.
BS 5440 Part 1	Flues.
BS 5440 Part 2	Ventilation.

Standard	Scope
BS 7074	Expansion vessels and ancillary equipment for sealed water systems.
BS 7593	Treatment of water in domestic hot water central heating systems.
BS 4814	Specification for Expansion Vessels using an internal diaphragm, for sealed hot water systems.
IGE/UP/7/1998	Guide for gas installations in timber framed housing.

Tab.4 In IE the following Code of Practice apply:

Standard	Scope
IS 813	Domestic Gas Installations.
The following standards give valuable additional information:	
BS 5546	Installation of hot water supplies for domestic purposes.
BS EN 12828	Heating systems in buildings.
BS EN 12831	Heating systems in buildings — Calculation of load.
BS EN 14336	Installation & commissioning of water based heating systems.
BS 7074	Expansion vessels and ancillary equipment for sealed water systems.
BS 7593	Treatment of water in domestic hot water central heating systems.

3.2 Technical data

3.2.1 Technical information



Important

All data in these sections are nominal and subject to normal production tolerances.

Tab.5 Technical settings for combination heaters with boilers

Baxi - Combi (C)			224 Combi 2	228 Combi 2
Condensing boiler			Yes	Yes
Low-temperature boiler ⁽¹⁾			No	No
B1 boiler			No	No
Cogeneration space heater			No	No
Combination heater			Yes	Yes
Rated heat output	<i>Prated</i>	kW	20	20
Useful heat output at rated heat output and high temperature setting ⁽²⁾	<i>P4</i>	kW	20	20
Useful heat output at 30% of rated heat output and low temperature setting ⁽¹⁾	<i>P1</i>	kW	6.7	6.7
Seasonal space heating energy efficiency	<i>ηs</i>	%	93	93
Useful efficiency at rated heat output and high temperature setting ⁽²⁾	<i>η4</i>	%	88.2	88
Useful efficiency at 30% of rated heat output and low temperature setting ⁽¹⁾	<i>η1</i>	%	97.9	97.8

Baxi - Combi (C)			224 Combi 2	228 Combi 2
Auxiliary electricity consumption				
Full load	<i>elmax</i>	kW	0.037	0.026
Partial load	<i>elmin</i>	kW	0.014	0.014
Standby mode	<i>PSB</i>	kW	0.004	0.004
Other items				
Heat loss on standby	<i>Pstby</i>	kW	0.04	0.04
Ignition burner power consumption	<i>Pign</i>	kW	-	-
Annual energy consumption	<i>QHE</i>	GJ	62	62
Sound power level, indoors	<i>LWA</i>	dB	50	49
Nitrogen oxide emissions	NOx	mg/kWh	23	21
Domestic hot water parameters				
Declared load profile			XL	XL
Daily electricity consumption	<i>Qelec</i>	kWh	0.176	0.185
Annual electricity consumption	<i>AEC</i>	kWh	39	41
Water heating energy efficiency				
	<i>ηwh</i>	%	88	85
Daily fuel consumption	<i>Qfuel</i>	kWh	22.03	22.72
Annual fuel consumption	<i>AFC</i>	GJ	17	17
(1) Low temperature means for condensing boilers 30°C, for low temperature boilers 37°C and for other heaters 50°C return temperature (at heater inlet).				
(2) High temperature setting means 60 °C return temperature at boiler inlet and 80 °C flow temperature at boiler outlet				

Tab.6 General

		224 Combi 2	228 Combi 2
Rated heat input (Qn) for domestic hot water	kW	24.7	28.9
Rated heat input (Qn) with domestic hot water tank	kW	-	-
Rated heat input (Qn) for heating	kW	20.6	20.6
Reduced heat input (Qn) 80/60 °C	kW	4.9	6.0
Rated heat output (Pn) for domestic hot water	kW	24	28.0
Rated heat output (Pn) with domestic hot water tank	kW	-	-
Rated heat output (Pn) 80/60 °C for heating	kW	20	20
Rated heat output (Pn) 50/30 °C for heating	kW	21.8	21.8
Reduced heat output (Pn) 80/60 °C	kW	4.8	5.8
Reduced heat output (Pn) 50/30 °C	kW	5.2	6.3
Rated efficiency 50/30 °C (Hi)	%	105.8	105.8

Tab.7 Characteristics of the heating circuit

		224 Combi 2	228 Combi 2
Maximum pressure	bar	2.5	2.5
Minimum pressure	bar	0.5	0.5
Temperature range for heating circuit	°C	25 - 80	25 - 80
Water capacity of expansion vessel	l	7	7

Tab.8 Characteristics of the domestic water circuit

		224 Combi 2	228 Combi 2
Minimum pressure	bar	0.8	0.8
Maximum pressure	bar	8.0	8.0
Minimum dynamic pressure	bar	0.15	0.15
Minimum water flow	l/min	2.0	2.0
Specific flow (D)	l/min	11.1	13.4
Temperature range for domestic water circuit	°C	35 - 60	35 - 60
Domestic water production with $\Delta T = 25\text{ °C}$	l/min	13.8	16.0
Domestic water production with $\Delta T = 35\text{ °C}$	l/min	9.8	11.4

Tab.9 Combustion characteristics

		224 Combi 2	228 Combi 2
G20 gas consumption (Qmax)	m ³ /h	2.61	3.06
G20 gas consumption (Qmax) with domestic hot water tank	m ³ /h	–	–
G20 gas consumption (Qmin)	m ³ /h	0.52	0.63
G31 propane gas consumption (Qmax)	kg/h	1.92	2.24
G31 propane gas consumption (Qmin)	kg/h	0.38	0.47
Diameter of separate discharge pipes	mm	80/80	80/80
Diameter of coaxial discharge pipes	mm	60/100	60/100
Flue gas mass flow rate (max)	kg/sec	0.011	0.013
Flue gas mass flow rate (max) with domestic hot water tank	kg/sec	–	–
Flue gas mass flow rate (min)	kg/sec	0.002	0.003

Tab.10 Electrical characteristics

		224 Combi 2	228 Combi 2
Power supply voltage	V	230	230
Power supply frequency	Hz	50	50
Rated electric power	W	90	85
Rated electrical output with domestic hot water tank	W	–	–

Tab.11 Other characteristics

		224 Combi 2	228 Combi 2
Humidity protection rating (EN 60529)	IP	X5D	X5D
Net weight when empty/filled with water	kg	26.5/28.5	27.5/29.5
Dimensions (height/width/depth)	mm	700/395/285	700/395/285

3.2.2 Features of the temperature sensors

Tab.12 Temperature sensor outdoor sensor (NTC1000 Beta 3419 1 kOhm @ 25 °C)

Temperature [°C]	-20	-15	-10	-5	0	5	10	15	20	25	30
Resistance [Ω]	7578	5861	4574	3600	2857	2284	1840	1492	1218	1000	827

NTC1000 Beta 3419 1 kOhm @ 25 °C

NTC1000 Beta 3419 1 kOhm @ 25 °C	가	바	다	라	나	다	라	바	나	다	라
NTC1000 Beta 3419 1 kOhm @ 25 °C	가	바	다	라	나	다	라	바	나	다	라

Tab.14 Flue gas temperature sensor (NTC20K Beta 3970 20kOhm@25°C)

Temperature [°C]	0	10	20	25	30	40	50	60	70	80	90	100
Resistance [Ω]	66050	40030	25030	20000	16090	10610	7166	4943	3478	2492	1816	1344

----->	110	120	130	140	150	160	170	180	190	-	-	-
----->	1009	768	592	461	364	290	233	189	155	-	-	-

3.3 Dimensions and connections

Fig.3 Dimensions and connections

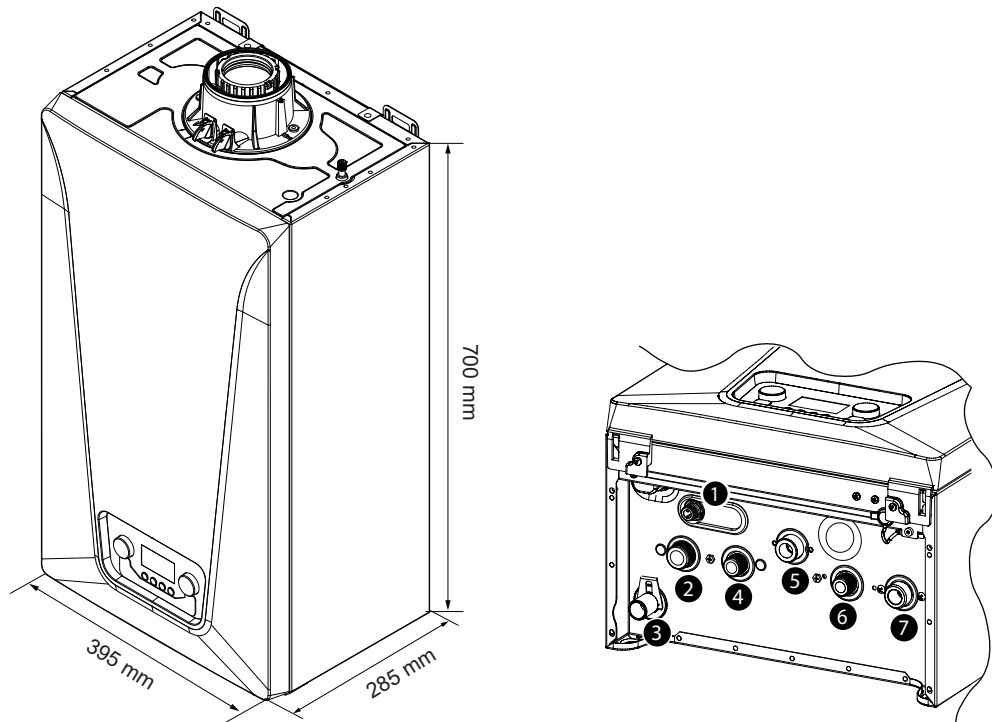

BO-0000199-1

- 1 Safety valve
- 2 Heating circuit flow fitting (G3/4")
- 3 Fitting for condensate discharge
- 4 DHW (Domestic Hot Water) outlet fitting (G1/2")
- 5 Gas inlet fitting (G3/4")
- 6 Domestic cold water inlet fitting (G1/2")
- 7 Heating circuit return fitting (G3/4")

Fig.4 Paper template

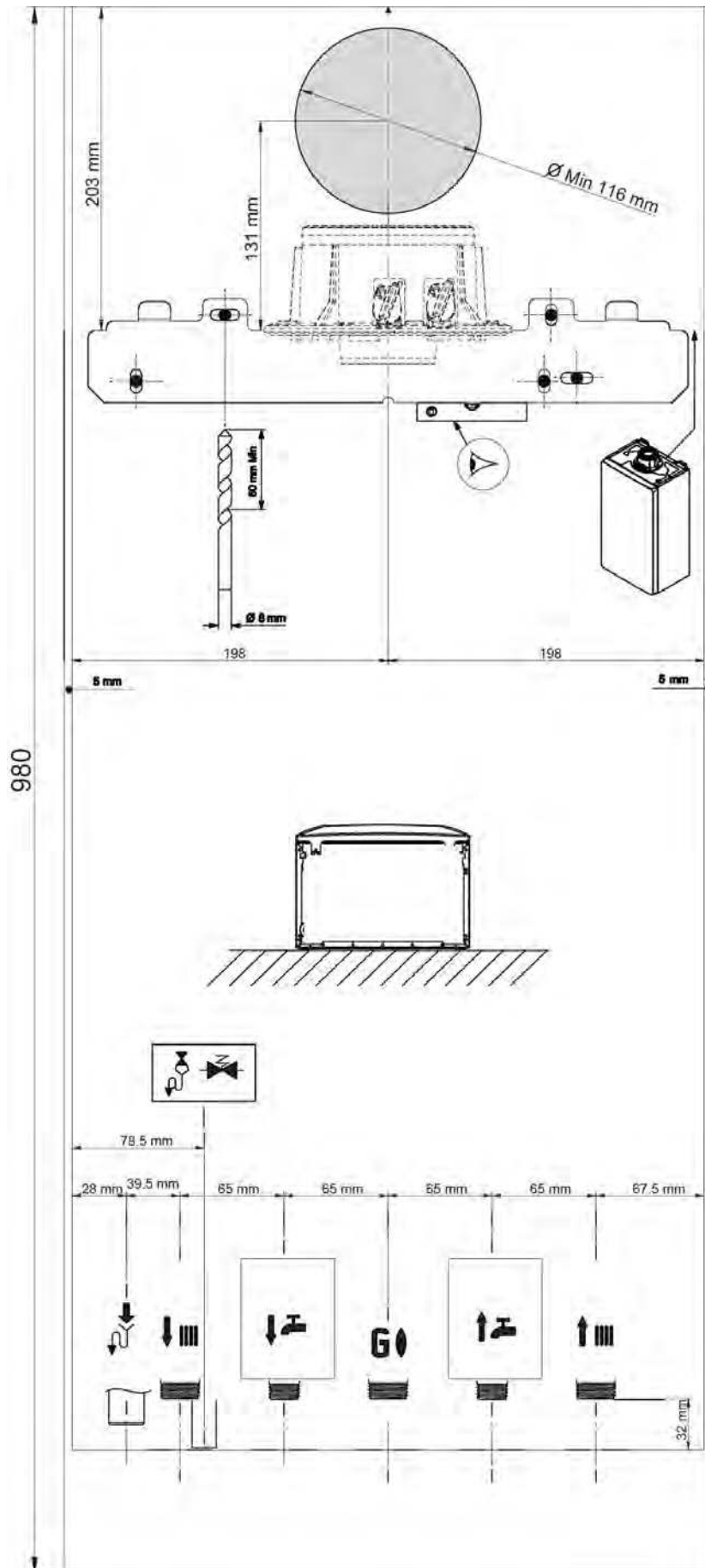

3.4 Electrical diagram

Fig.5 Boiler electrical wiring diagram

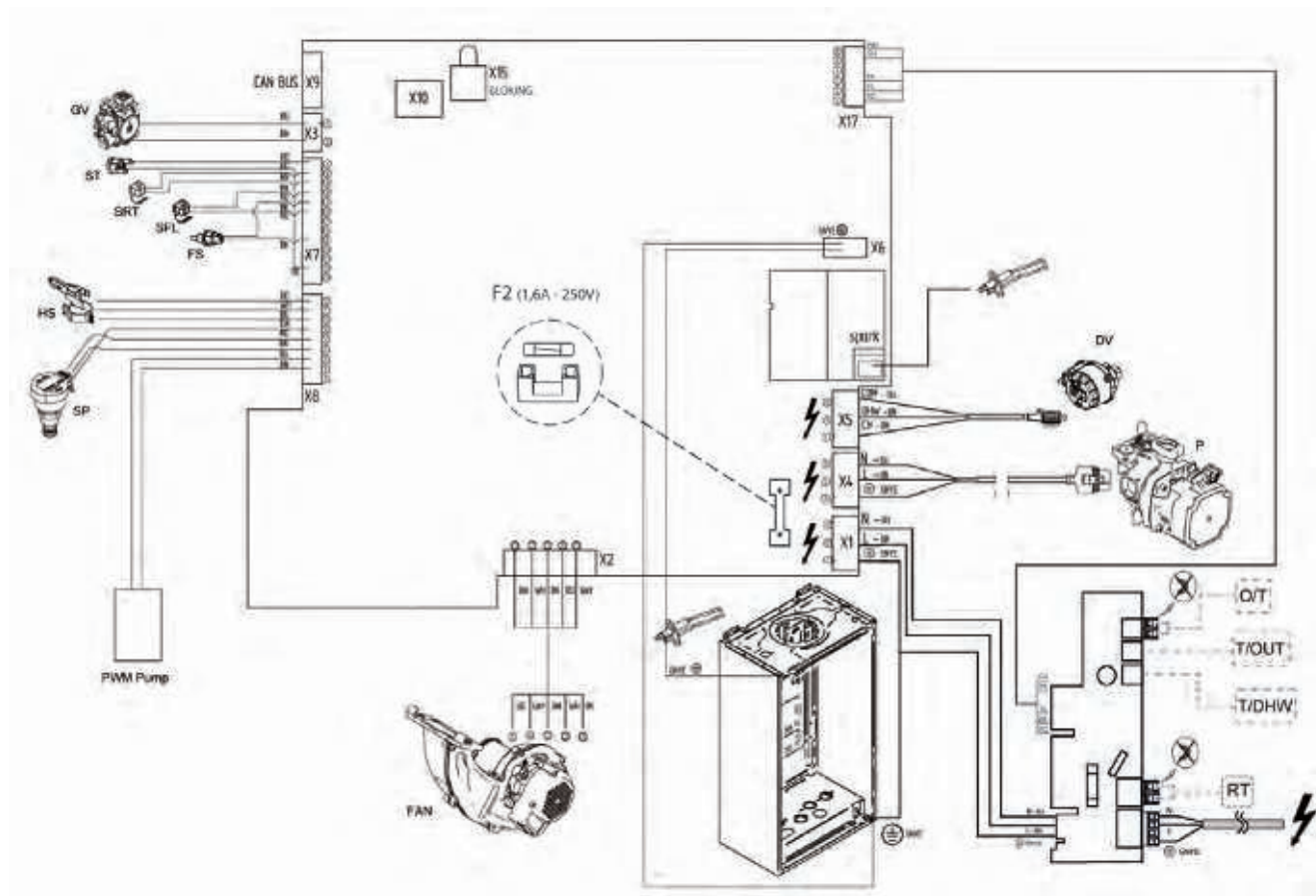

Tab.15 Electrical connections

X1	Power supply: L: Live 230V – 50 Hz N: Neutral ⊕ : Earthing connector	X9	CAN connection
X2	Fan supply (FAN)	X10	Service interface
X3	Gas valve (GV)	X15	Boiler stoppage (with open contact)
X4	Pump power supply	X17	Open Therm room unit (OT)
X5	3-way valve motor power supply	X17	Outside sensor (T/OUT)
X6	Earth connections	X17	External tank sensor - accessory (T/DHW)
X7	Sensors: Limit thermostat (ST) Installation return temperature (SRT) Installation flow temperature (SFL) Flue gas temperature (FS)	RT	Room thermostat contact (230 V)
X8	Sensors: DHW flowmeter (HS) Heating circuit pressure switch (SP) Pump PWM signal (PWM PUMP)		

Tab.16 Cable colour key

BK	Black	GY	Grey
BN	Brown	RD	Red
BU	Blue (and light blue)	WH	White
GNYE	Green/Yellow	YE	Yellow

4 Description of the product

4.1 General description

The purpose of this gas-fuelled condensing boiler is to heat water to a temperature that is lower than boiling point at atmospheric pressure. It must be connected to a heating installation and to a domestic hot water distribution system that is compatible with its power and performance ratings. Features of this boiler:

- Low pollutant emissions,
- High-efficiency heating,
- Combustion products discharged through a concentric connector,
- Front control panel with display,
- Lightweight and compact.

4.2 Operating principle

4.2.1 Air-gas adjustment

The air is drawn in by the fan and gas injected directly at the height of the venturi. The fan revolution speed is regulated automatically by the electronic board based on the adjustment settings. The gas and air are mixed in the manifold. The gas/air ratio ensures that the quantity of gas and air are adjusted correctly to always obtain optimal combustion. The gas/air mixture is fed into the burner at the front of the exchanger.

Here, the electric igniter triggers the mixture with a series of sparks that burn, producing thermal energy.

4.2.2 Combustion

The burner heats the heating water circulating in the heat exchanger. When the temperature of the combustion gas is lower than the dew point (around 55 °C), the water vapour contained in the combustion gas condenses in the flue gas side of the heat exchanger. The heat recovered during this condensation process (the latent heat or condensing heat) is also transferred to the heating water. Once cooled, the combustion gases are discharged through the exhaust pipe. The condensed water is discharged through a siphon.

4.2.3 Heating and domestic hot water production

In boilers used for heating and for producing domestic hot water, an integrated plate heat exchanger heats the domestic water. The heated water is then channelled to the heating installation or to the plate heat exchanger via a three-way valve. A flow sensor detects that a hot water tap has been turned on and communicates this to the PCB, which switches the three-way valve to the hot water position and activates the pump. The three-way valve is spring-loaded and only consumes electricity when switching from one position to another. Precedence is given to a heat request in domestic water mode.

4.2.4 Schematic diagram

Fig.6 Schematic diagram

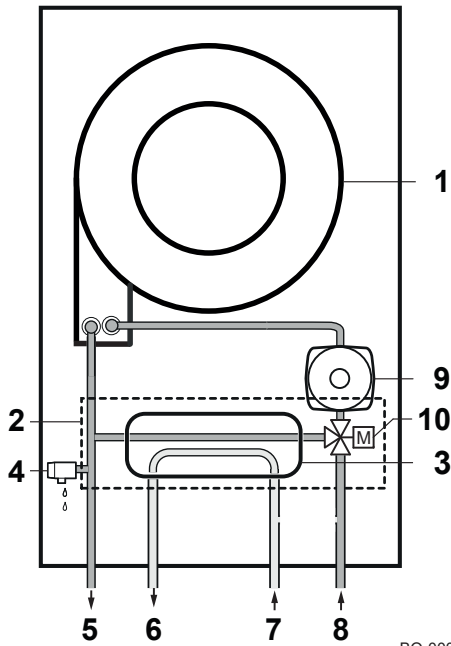

- 1 Heat exchanger (heating)
- 2 Water unit
- 3 Plate heat exchanger (DHW)
- 4 Safety valve
- 5 Heating flow
- 6 DHW outlet (G1/2")
- 7 DHW inlet (G1/2")
- 8 Heating return
- 9 Pump (heating circuit)
- 10 Motorised three-way valve

BO-0000144

4.3 MAIN COMPONENTS

Fig.7 Functional diagram

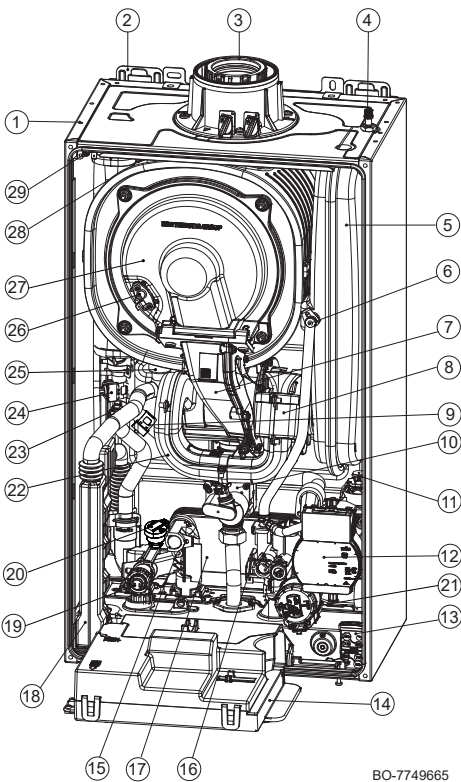

- 1. Construction
- 2. Hooks for fastening the bracket to the wall
- 3. Flue gas tower
- 4. Expansion vessel air control/filling valve
- 5. Expansion vessel
- 6. Hydraulic circuit-expansion vessel connection pipe
- 7. Air-gas collector
- 8. Fan (air-gas assembly: Control board and mixer valve)
- 9. Heating return sensor
- 10. Gas valve
- 11. Heating system and pump venting valve
- 12. Pump
- 13. Cable gland
- 14. Control panel with boiler PCB and display
- 15. Domestic hot water plate heat exchanger fastening screws
- 16. Domestic hot water priority sensor
- 17. Domestic hot water plate heat exchanger
- 18. Siphon
- 19. Hydraulic safety valve (3 bar)
- 20. Hydraulic pressure gauge
- 21. 3-way valve
- 22. Air-gas silencer assembly
- 23. Heating circuit water flow sensor (°C)
- 24. Safety thermostat (limit)
- 25. Condensate drain pipe connection towards discharge
- 26. Detection/ignition electrode
- 27. Burner flange
- 28. Flue gas temperature sensor
- 29. Boiler earthing socket

BO-7749665

4.4 Control panel description

Fig.8 Control panel

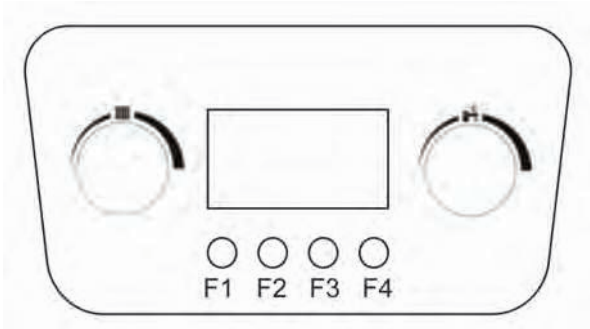
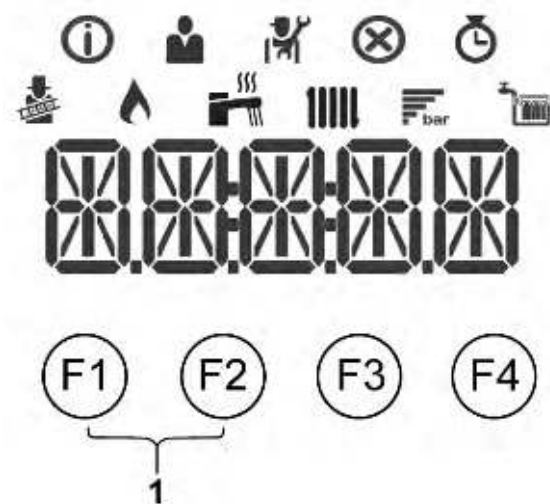



Fig.9 Display screen













4.4.1 Description of the control panel

Knobs

-  **HEATING:** Using this knob you can modify the flow temperature for the heating installation (heating setpoint 25-80 °C).
 - turn the knob anti-clockwise to reduce the temperature or to the left to scroll through the menus. With an outside sensor connected it is possible to limit the setpoint value;
 - turn the knob clockwise to increase the temperature or to the right to scroll through the menus.
-  **DOMESTIC HOT WATER:** Using this knob you can modify the domestic hot water temperature (DHW setpoint 35÷60 °C) or scroll through the menus to the left and right:
 - turn anti-clockwise to reduce the temperature.
 - turn clockwise to increase the temperature.

Icons

-  Chimney sweep mode is enabled (forced full load or low load for CO₂ measurement).
-  The burner is on.
-  Display of the system water pressure.
-  DHW operation is enabled.
-  CH operation is enabled.
-  Information menu: read out various current values.
-  User menu: user-level parameters can be configured.
-  Installer menu: installer-level parameter can be configured.
-  Error menu: errors can be read out.
-  Counter menu: various counters can be read out.

Buttons

- F1** Back (previous menu)
- F2** Manual reset
- F3** Menu
- F4** Confirms selection or value.
- 1** Chimney sweep mode:
Press keys **F1** and **F2** simultaneously.

4.5 Contents of the package

The boiler is delivered in a package comprising:

- a wall-hung gas boiler;
- a bracket for fastening the boiler to the wall;
- a flue gas fitting;
- a three-pole cable for connecting the power supply;
- a paper template;
- an installation and service manual;
- a user Guide;
- A condensate drain pipe;
- Dowel/screw kit for fastening the boiler to a wall.

4.6 Accessories & options

Consult the sales catalogue for all available accessories and options.

5 Before installation

5.1 Installation standards and rules



Warning

Installation, repair and maintenance must only be carried out by a competent person. This document is intended for use by competent persons.

Installation must be carried out in accordance with the prevailing regulations, the code of practice and the recommendations in these instructions.

Installation must also respect the following points:

- This instruction manual and any other applicable documentation
- Building Regulations
- British Standards
- Gas Safety Regulations
- Water Supply Regulations

5.2 Installation requirements

5.2.1 Gas supply

The gas installation should be in accordance with the relevant standards. In GB this is BS 6891 (NG). In IE this is the current edition of IS 813 Domestic Gas Installations.

The connection to the appliance is a 22mm copper tail located at the rear of the gas service cock.

Ensure that the pipework from the meter to the appliance is of adequate size, and the demands of any other gas appliances in the property are taken into consideration. Do not use pipes of a smaller diameter than the boiler gas connection (22mm) UNLESS the stated gas rate can be achieved with pipe of lesser diameter and with all other gas appliances operating at maximum rate.

5.2.2 Electrical supply

External wiring must be correctly earthed, polarised and in accordance with relevant regulations/rules. In GB this is the current IEE Wiring Regulations. In IE reference should be made to the current edition of ETCI rules.

The mains supply is 230V ~ 50Hz fused at 3A.



Important

The method of connection to the electricity supply must facilitate complete electrical isolation of the appliance.

Connection may be via a fused double-pole isolator with a contact separation of at least 3mm in all poles and servicing the boiler and system controls only.

The boiler must be connected to the mains fused 3A 230V 50HZ supply & control system using cable of 3 core 0.75mm 3183Y multi strand flexible type.

i Important

Any wiring to the boiler, from either the mains or an external control, MUST be cable of the following specification:- 0.75mm 3183/4/5Y (depending on installation) multi strand flexible cable conforming to BS 50525-2-11.

Cable of the above specification is sufficiently flexible to withstand normal regular opening and closing of the facia/control box as expected during routine servicing and other maintenance work.

Use ONLY cable glands supplied with the boiler, or provided as spares by the manufacturer.

Under no circumstances must solid core cable be used as it is not intended for applications where movement may occur. The use of solid core cable could result in situations potentially hazardous to health.

These points must be considered when initially wiring the boiler to the installation, and if replacing any wiring during the service life of the boiler.

5.2.3 Hard water area

i Important

Only water that has NOT been artificially softened must be used when filling or re-pressurising the primary system. If the mains cold water to the property is fitted with an artificial softening/treatment device the source utilised to fill or re-pressurise the system must be upstream of such a device.

5.2.4 Bypass

The boiler utilises the primary side of the DHW plate heat exchanger as an automatic integral bypass.

5.2.5 System control

Further external controls (e.g. room thermostat sensors) MUST be fitted to optimise the economical operation of the boiler in accordance with Part L of the Building Regulations. A range of optional controls is available. Full details are contained in the relevant Sales Literature.

Any proprietary OpenTherm control MUST allow individual adjustment of CH and DHW temperature.

5.2.6 Treatment of water circulating systems

All recirculatory water systems will be subject to corrosion unless an appropriate water treatment is applied. This means that the efficiency of the system will deteriorate as corrosion sludge accumulates within the system, risking damage to pump and valves, boiler noise and circulation problems.

When fitting new systems flux will be evident within the system, which can lead to damage of system components.

BS 7593 gives extensive recommendations on system cleansing and water treatment.

All systems must be thoroughly drained and flushed out using appropriate proprietary flushing agent.

A suitable inhibitor must then be added to the system.

All system additives (flushing agents, cleansers, inhibitors etc.) must comply with the requirements of BS 7593. Full instructions are supplied with the products and for further information contact the additive manufacturer directly or consult their website.

**Important**

Failure to flush and add inhibitor to the system will invalidate the appliance warranty.

It is important to check the inhibitor concentration after installation, system modification and at every service in accordance with the inhibitor manufacturer. (Test kits are available from inhibitor stockists.)

For information or advice regarding any of the above contact Baxi Customer Support 0344 871 1545.

5.2.7 Showers

If a shower control is supplied from the appliance it should be of the thermostatic or pressure balanced type. Thermostatic type shower valves provide the best comfort and guard against water at too high a temperature. Existing controls may not be suitable - refer to the shower valve manufacturer.

5.2.8 Expansion vessel (CH only)

The appliance expansion vessel is pre-charged to 1.0 bar. Therefore, the minimum cold fill pressure is 1.0 bar. The vessel is suitable for correct operation for system capacities up to 100 litres. For greater system capacities an additional expansion vessel must be fitted.

For GB refer to BS 7074 Pt 1. For IE, the current edition of IS 813 Domestic Gas Installations.

Checking the charge pressure of the vessel - to check the charge accurately ensure the system is cold. It is also necessary to relieve the pressure by draining the boiler. Using a suitable gauge check the pressure at the valve on the underside of the vessel. Adjust the pressure as required and repressurise the system.

5.2.9 Safety pressure relief valve

- 1 Discharge pipe
- 2 Pressure relief valve
- A The end of the pipe should terminate facing down and towards the wall

**See**

BS 6798 for full details.

The pressure relief valve is set at 3 bar, therefore all pipework, fittings, etc. should be suitable for pressures in excess of 3 bar and temperature in excess of 100°C.

The pressure relief discharge pipe should be not less than 15mm diameter, run continuously downward, and discharge outside the building, preferably over a drain. It should be routed in such a manner that no hazard occurs to occupants or causes damage to wiring or electrical components. If it is anticipated that any part of the pipe may be subject to freezing it should be suitably insulated. The end of the pipe should terminate facing down and towards the wall.

The discharge must not be above a window, entrance or other public access. Consideration must be given to the possibility that boiling water/steam could discharge from the pipe.

**Important**

The relief valve must never be used to drain the system.

A remote relief valve kit is available to enable the boiler to be installed in cellars or similar locations below outside ground level.

A boiler discharge pump is available which will dispose of both condensate & high temperature water from the relief valve. It has a maximum head of 5 metres.

Fig.10 Discharge pipe

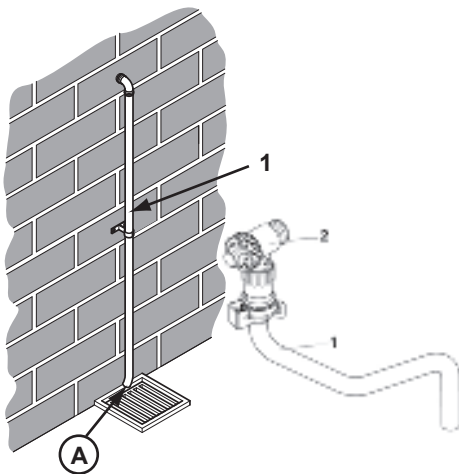

5.3 Flow rate/head at the plate characteristics

Fig.11 Graph of flow rate/head at the plate

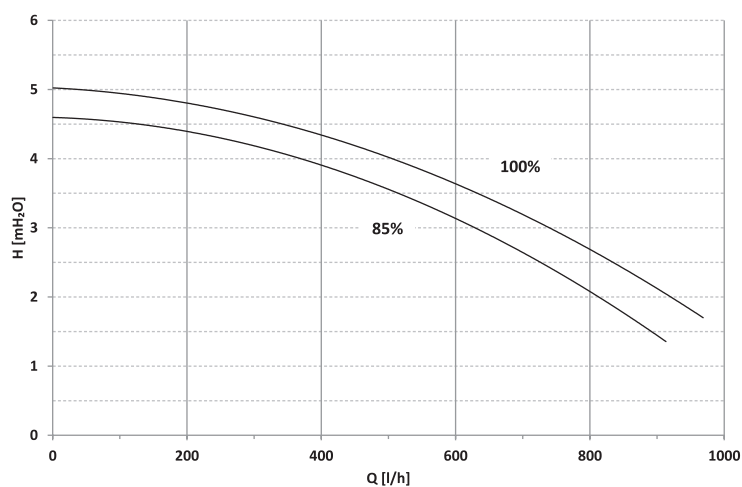

BO-0000226

Tab.17 Description of graph of flow rate/head at the plate

Q	Flow volume
h	Dynamic head
85 %	Minimum modulation value in heating mode
100%	Maximum value in heating mode

To prevent flow noise, you must pay attention to the hydraulic design of the heating installation.

The system uses a high-head, modulating pump that is suitable for use on any type of one- or two-pipe heating system. The automatic air vent valve built into the pump body enables fast venting of the heating system.

Operation of the pump in DHW mode → 100% fixed.

Operation of the pump in heating mode → modulating by 85% to 100% .

5.4 Choice of the location

5.4.1 Location of the boiler

The boiler may be fitted to any suitable wall with the flue passing through an outside wall or roof and discharging to atmosphere in a position permitting satisfactory removal of combustion products and providing an adequate air supply. The boiler should be fitted within the building unless otherwise protected by a suitable enclosure i.e. garage or outhouse. (The boiler may be fitted inside a cupboard.)

Where the boiler is sited in an unheated enclosure and during periods when the heating system is to be unused it is recommended that the permanent live is left on to give BOILER frost protection. **NOTE: THIS WILL NOT PROTECT THE SYSTEM !**

If the boiler is fitted in a room containing a bath or shower reference must be made to the relevant requirements.

In GB this is the current IEE Wiring Regulations and Building Regulations.

In IE reference should be made to the current edition of IS 813 Domestic Gas Installations and the current ETCI rules.

It is not necessary to protect any surface the boiler is mounted on from heat generated during normal operation unless required by local authority regulations.

If the boiler is to be fitted into a building of timber frame construction then reference must be made to the current edition of Institute of Gas Engineers Publication IGE/UP/7 (Gas Installations in Timber Framed Housing).

Fig.12 Bathroom 1 and 2

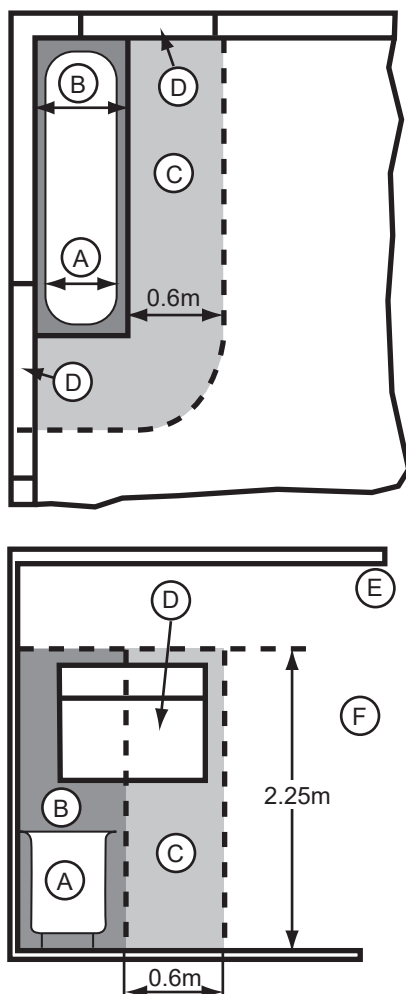

PN-0000400

5.4.2 Bath and shower rooms

- A Zone 0
- B Zone 1
- C Zone 2
- D Window recess Zone 2
- E Ceiling
- F Outside zones



Important

The boiler has a protection rating of IPX5D and if installed in a room containing a bath or shower can be within Zone 2 (but not 0 or 1).



Bathroom 1 and 2 (in GB only) shows zone dimensions for a bathtub. For other examples refer to the Current IEE Wiring Regulations). Reference must be made to the relevant requirements.

In GB this is the current IEE. Wiring Regulations and Building Regulations.

In IE reference should be made to the current edition of IS 813 "Domestic Gas Installations" and the current ETCI rules.

5.4.3 Ventilation

Where the appliance is installed in a cupboard or compartment, no air vents are required. BS 5440: Part 2 refers to room sealed appliances installed in compartments. The appliance will run sufficiently cool without ventilation.

5.4.4 Condensate drain

It is strongly recommended to discharge internally into the household drainage system. If connecting to a rain water drain, that drain MUST discharge into a foul drain.

- 1 Pipework.
- 2 Insulation.
- 3 50mm per metre of pipe run — 2.5° minimum run.
- 4 450mm minimum is applicable to properties up to 3 storeys. For multi-storey building installations consult BS 6798.
- 5 Boiler.
- 6 Sink.
- 7 Pipe must terminate above water level but below surrounding surface. Cut end at 45°.
- 8 Holes in the soak-away must face away from the building.
- 9 500mm minimum.
- 10 Basement or similar (heated)
- 11 Condensate pump
- 12 Unheated Location (e.g. Garage)

Fig.13 Pipework and method of termination

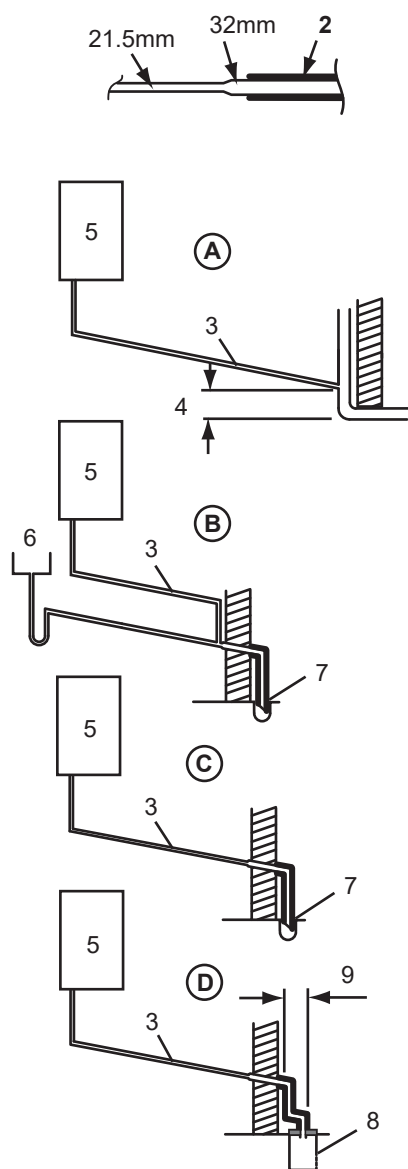

PN-0000389

Tab.18 Examples are shown of the following methods of termination

Key	Description
A	Termination to an internal soil and vent pipe.
B	External termination via internal discharge branch e.g. sink waste — downstream (It is NOT RECOMMENDED to connect upstream of the sink or other waste water receptacle!)
C	Termination to a drain or gully.
D	Termination to a purpose made soakaway Further specific requirements for soakaway design are referred to in BS 6798
E	Pumped into an internal discharge branch (e.g. sink waste) downstream of the trap.
F	Pumped into an external soil and vent pipe.
G	Termination to a drain or gully with extended external run and trace heating. The "Trace Heating" element must be installed in accordance with the instructions supplied. External runs and those in unheated locations still require insulation.

Fig.14 Methods of termination continued

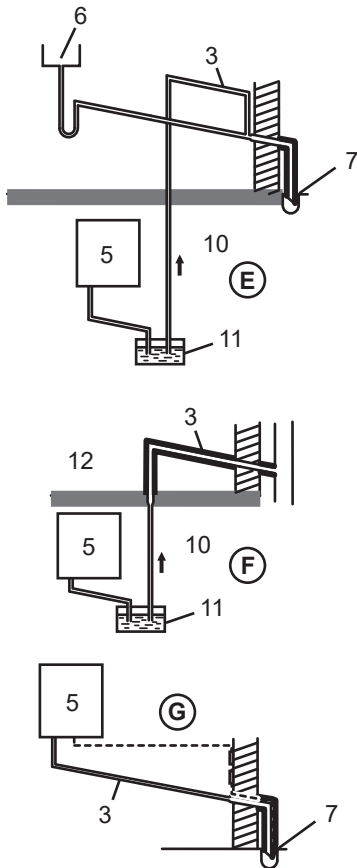

PN-0000455

i Important

Failure to install the condensate discharge pipework correctly will affect the reliable operation of the boiler.

Careful consideration must be given to the possibility of the pipework being subject to freezing conditions and appropriate measures taken to prevent blockage. Correct installation in accordance with this section will considerably minimise the likelihood of blockage and subsequent boiler lock-out.

A condensate discharge pump and pipe "Trace Heating" are available as accessories.

The condensate discharge pipe **MUST NOT RISE** at any point along its length. There **MUST** be a fall of **AT LEAST 2.5°** (50mm per metre) along the entire run **EXCEPT** when employing a suitable condensate pump in basement and cellar or similar applications.

The boiler condensate trap incorporates a seal of 75mm, therefore it is unnecessary to install an air break and trap in the discharge pipework.

The condensate outlet will accept 21.5mm (³/₄in) plastic overflow pipe. **It is strongly recommended that this discharges internally into the household drainage system.** Where this is not possible, discharge into an outside drain is permissible providing every possible precaution is taken to prevent freezing.

Ensure the discharge of condensate complies with any national or local regulations in force. **BS 6798 & Part H1 of the Building Regulations give further detailed guidance.**

The discharge pipe should be run in a proprietary drain pipe material e.g. PVC, PVC-U, ABS, PVC-C or PP.

Metal pipework is **NOT** suitable for use in condensate discharge systems.

The pipe should be a minimum of 21.5mm diameter and must be supported using suitably spaced clips of the correct design to prevent sagging.

It is advisable that the full length of condensate pipe is run internally and preferably be less than 3 metres.

Internal runs greater than 3 metres or runs in cold areas should use 32mm waste pipe.

External runs MUST be a MINIMUM of 32mm and fully insulated with material suitable for external use.

If the boiler is fitted in an unheated location the entire condensate discharge pipe should be treated as an external run and sized and insulated accordingly.

In all cases discharge pipe must be installed to aid disposal of the condensate. To reduce the risk of condensate being trapped, as few bends and fittings as possible should be used and any burrs on cut pipe removed.

When discharging condensate into a soil stack or waste pipe the effects of existing plumbing must be considered. If soil pipes or waste pipes are subjected to internal pressure fluctuations when WC's are flushed or sinks emptied then backpressure may force water out of the boiler trap and cause appliance lockout.

A boiler discharge pump is available which will dispose of both condensate & high temperature water from the relief valve. It has a maximum head of 5 metres. Follow the instructions supplied with the pump.

Condensate Drain Pipe "Trace Heating" Elements are available in various lengths, 1, 2, 3 & 5 metres. Where the drain is between 3 & 5 metres a 5 metre kit can be used and "doubled back" upon itself.

It is possible to fit the element externally on the condensate drain or internally as detailed in the instructions provided.

The fitting of a "Trace Heating" Element is **NOT** a substitute for correct installation of the condensate drain. **ALL** requirements in this section must still be adhered to.

5.4.5 Clearances

Fig.15 Clearances

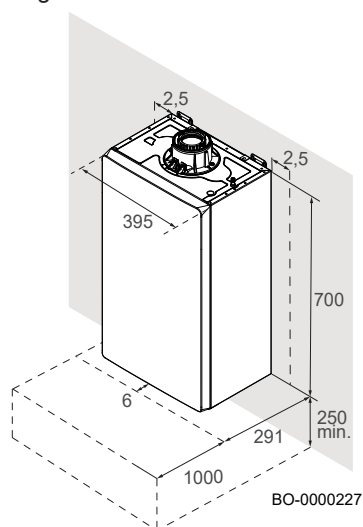

A flat vertical area is required for the installation of the boiler and it should be capable of bearing the weight of the boiler when full of water.

These dimensions include the necessary clearances around the boiler for case removal, spanner access and air movement. Additional clearances may be required for the passage of pipes around local obstructions such as joists running parallel to the front face of the boiler.

In the diagram these are MINIMUM recommended dimensions. Greater clearance will aid installation and maintenance.

5.4.6 Flue/chimney location

The following guidelines indicate the general requirements for siting balanced flue terminals. For GB recommendations are given in BS 5440 Pt 1. For IE recommendations are given in the current edition of I.S. 813 Domestic Gas Installations.

i Important

Due to the nature of the boiler a plume of water vapour will be discharged from the flue. This should be taken into account when siting the flue terminal.

Fig.16 Flue outlets

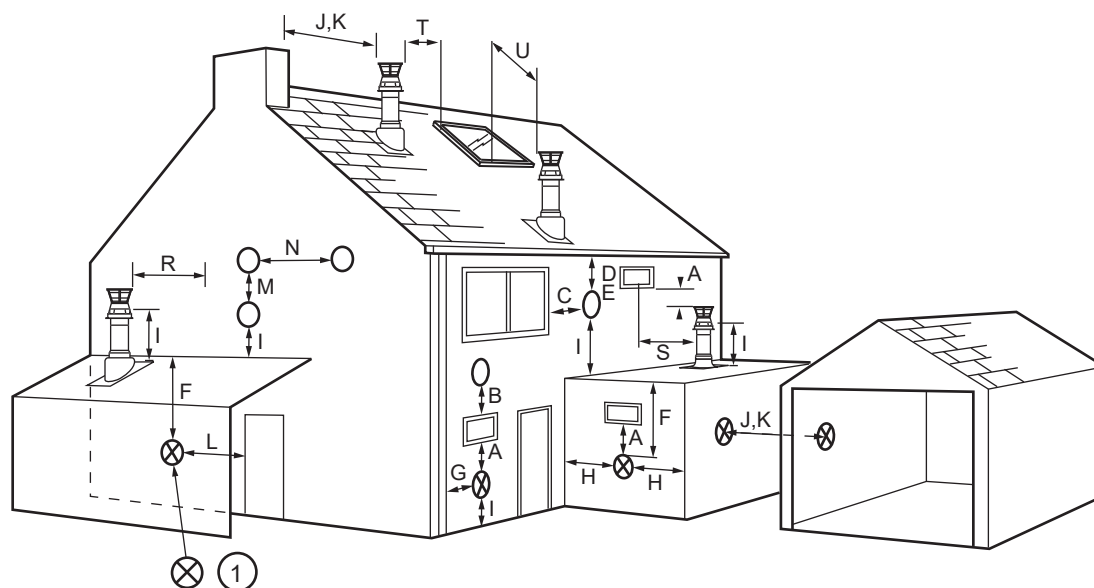

PN-0000456

1 Flue positions marked ⊗ require a flue terminal guard.

Tab.19 Terminal position with minimum distance

Key	Description	mm	Key	Description	mm
A ⁽¹⁾	Directly below an opening, air brick opening window etc.	300	J	From a surface or boundary line facing a terminal	600
B ⁽¹⁾	Above an opening, air brick, opening window etc.	300	K	From a terminal facing a terminal (Horizontal flue)	1200
				From a terminal facing a terminal (Vertical flue)	600

Key	Description	mm	Key	Description	mm
C ⁽¹⁾	Horizontally to an opening, air brick, opening window etc.	300	L	From an opening in carport (e.g. door, window) into the dwelling	1200
D ⁽²⁾	Below gutters, soil pipes or drain pipes	25 (75)	M	Vertically from a terminal on the same wall	1500
E ⁽²⁾	Below eaves	25 (200)	N	Horizontally from a terminal on the same wall	300
F ⁽²⁾	Below balconies or car port roof	25 (200)	R	From adjacent wall to flue (vertical only)	300
G ⁽²⁾	From a vertical drain pipe or soil pipe	25 (150)	S	From an adjacent opening window (vertical only)	1000
H ⁽²⁾	From an internal or external corner	25 (300)	T	Adjacent to windows or openings on pitched and flat roofs	600
I	Above ground, roof, or balcony level	300	U	Below windows or openings on pitched roofs	2000

(1) In addition, the terminal should be no nearer than 150mm to an opening in the building fabric formed for the purpose of accommodating a built-in element such as a window frame.

(2) Only ONE 25mm clearance is allowed per installation. If one of the dimension D,E,F,G or H is 25mm then the remainder MUST be as shown in brackets, in accordance with BS 5440-1.



Important

Under car ports we recommend the use of the plume displacement kit. The terminal position must ensure the safe and nuisance-free dispersal of combustion products.

If the terminal discharges onto a pathway or passageway, check that combustion products will not cause a nuisance and that the terminal will not obstruct the passageway.

If a terminal is less than 2 metres above a balcony, above ground or above a flat roof to which people have access, then a suitable terminal guard must be provided.

Fig.17 Property boundary

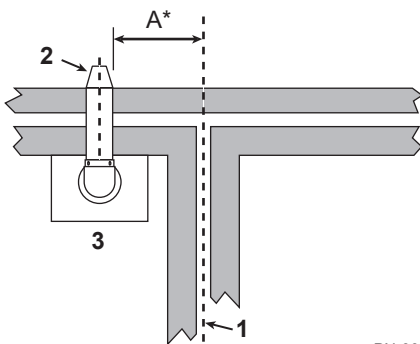

- 1 Property boundary line
- 2 Terminal assembly
- 3 Top view rear flue
- A 300mm minimum*

*Reduction to the boundary is possible down to 25mm but the flue deflector must be used.



Important

The distance from a fanned draught appliance terminal installed parallel to a boundary may not be less than 300mm in accordance with the diagram opposite.

PN-0000457

Fig.18 Plume displacement kit

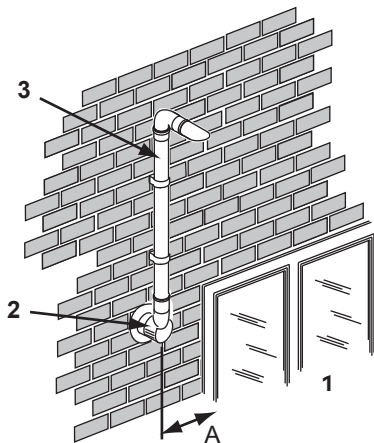

PN-0000458

- 1 Opening window or door
- 2 Air inlet
- 3 Plume displacement kit
- A 150mm minimum

**Important**

If fitting a Plume Displacement Flue Kit, the air inlet must be a minimum of 150mm from any opening windows or doors.

**Important**

The Plume Displacement flue gas discharge terminal and air inlet must always terminate in the same pressure zone i.e. on the same facing wall.

Fig.19 Horizontal flues

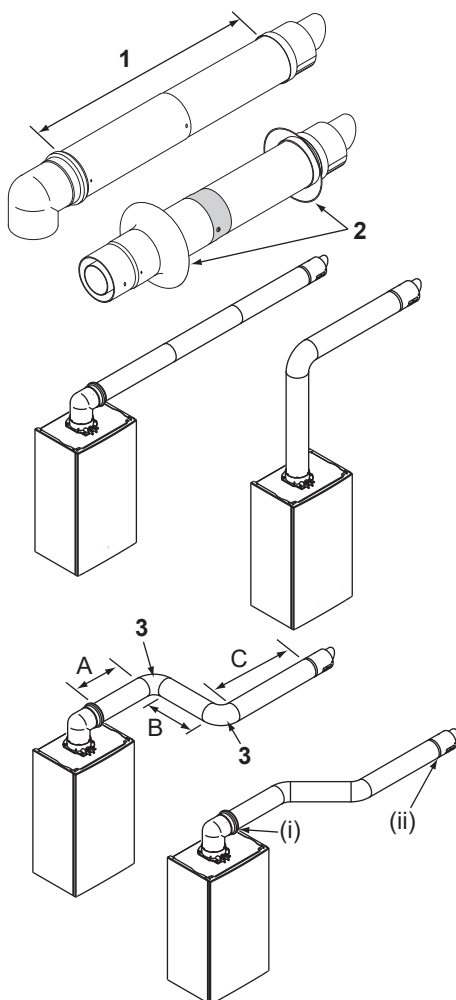

PN-0000459

- 1 315mm to 500mm
- 2 Flue trims
- 3 This bend is equivalent to 1 metre

Total equivalent length = A+B+C+2x90° bends

**Important**

Horizontal flue extensions should always be installed with a fall of at least 1.5° from the terminal to allow condensate to run back to the boiler.

The standard telescopic flue is suitable only for horizontal termination applications. It allows for lengths between 315mm and 500mm from elbow to terminal without the need for cutting. Extensions of 250mm, 500mm and 1m are available.

All fittings should be fully engaged. The approximate engagement is 40mm. Apply the lubricant supplied to the seal on each fitting to aid assembly.

Tab.20 Maximum permissible equivalent flue lengths are:-

Horizontal concentric	60/100 Diameter	80/125 Diameter
	10 metres	20 metres

Any additional "in line" bends in the flue system must be taken into consideration.

Tab.21 Their equivalent lengths are:-

Concentric pipes	135° bend	0.5 metres
	93° bend	1.0 metres

The elbow supplied with the standard horizontal telescopic flue kit is not included in any equivalent length calculations.

**Important**

Flue length is measured from point (i) to (ii) as shown.

**See**

Read this section in conjunction with the Flue Installation Guide supplied with the boiler. This document includes details of vertical flue/chimney systems and plume displacement kits.



Warning

SUPPORT - All flue systems **MUST** be securely supported at a **MINIMUM** of once every metre & every change of direction. It is recommended that every straight piece is supported irrespective of length. Additional supports are available as accessories.

VOIDS - Consideration must be given to flue systems in voids and the provision of adequate access for subsequent periodic visual inspection.

Fig.20 Flexible flue trims

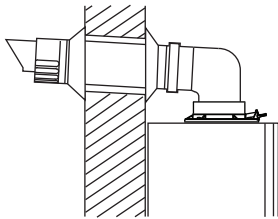

PN-0000390

5.4.8 Flue/chimney trim

The flexible flue trims supplied can be fitted on the outer and inner faces of the wall of installation.

Fig.21 Terminal guard

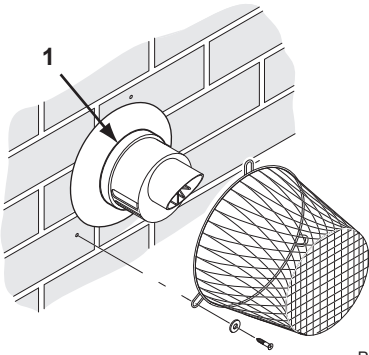

PN-0000460

5.4.9 Terminal guard

- 1 **ENSURE THAT NO PART OF THE WHITE OUTER CHIMNEY DUCT IS VISIBLE.**

When codes of practice dictate the use of terminal guards Multifit accessory part no. 720627901 can be used



Important

This guard is not compatible with Flue Deflector referred to below.

There must be a clearance of at least 50mm between any part of the terminal and the guard.

When ordering a terminal guard, quote the appliance name and model number.

The flue terminal guard should be positioned centrally over the terminal and fixed as illustrated.

Fig.22 Flue deflector

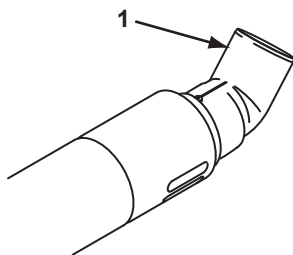

PN-0000461

5.4.10 Flue/chimney deflector

- 1 Flue deflector

Push the flue deflector over the terminal end. It may point upwards as shown, or up to 45° either way from vertical. Secure the deflector to the terminal with screws provided.

5.4.11 Flue/chimney accessories



See

For full details of Flue Accessories (elbows, extensions, clamps etc.) refer to the Flue Installation Guide supplied in the literature pack.

Fig.23 Position of the data plate

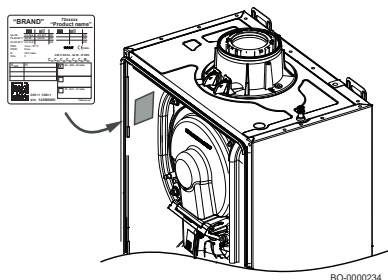
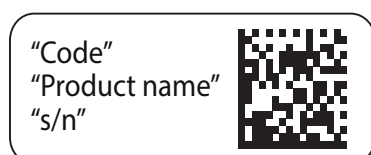

Fig.24 Data plate



BO-000010

Fig.25 Service label



BO-000012

5.4.12 Data plate and boiler service label

The data plate is located on the top part of the boiler. The data plate provides important information about the appliance (see the sample data plate shown in the figure):

Tab.22 Description of the data plate

"BRAND"	Commercial brand.
"Code"	Product code.
"Product name"	Model name
Qn Hi	Nominal input (lower heating value).
Pn	Effective rated output (flow 80°C return 60°C).
PMS	Maximum heating circuit pressure (bar).
PMW	Maximum domestic water circuit pressure (bar).
D	Specific flow rate (l/min).
NOx	NOx class.
IP	Protection rating.
V-Hz-W	Power supply and output.
Bxx/Cxx	Flue gas exhaust type.
I _{2H}	Gas category used (depends on the country of use).
CN1/CN2	Factory parameters.
s/n	Serial number.

Tab.23 Service label description

"Code"	Product code.
"Product name"	Model name.
"s/n"	Serial number.

5.5 Transport

Transport the packaged appliance horizontally using a suitable cart. The boiler may be transported vertically using a two-wheel cart, only for short distances.



Warning

Moving the boiler is a job for two people.

5.6 Unpacking & initial preparation

5.6.1 Unpacking



Caution

RISK ASSESSMENT - Before commencing the installation it is recommended that the "Five Steps to Risk Assessment" document published by the HSE is consulted, and an assessment performed as described. **GAS SUPPLY** - The gas supply, gas type and pressure must be checked for suitability before connection.



See

Handling, page 9 before unpacking or lifting the boiler.

To unpack the boiler:

1. Remove the banding and the cardboard sleeve.
2. Remove the polystyrene top piece and installation kit.
3. Snap off the rear part of the polystyrene bottom piece.



Important

Polystyrene base should be removed completely if fitting the boiler into a space with minimum side clearances of 5 mm each side.



Important

If removing the polystyrene base, the sealing caps can also be removed at this stage. **Care must be taken to avoid damage from any residual water in the boiler.**

Fig.26 Unpacking the boiler

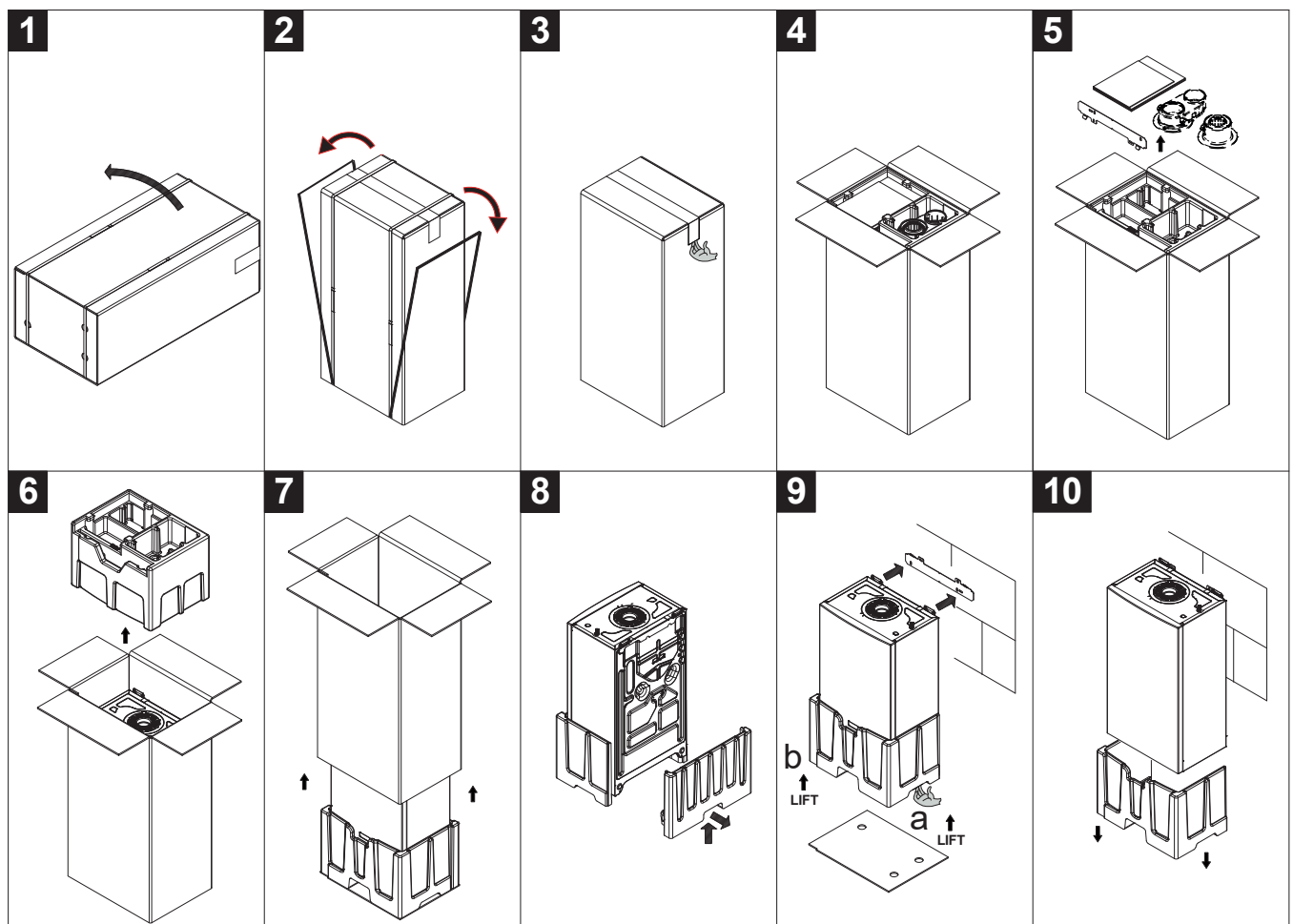

BO-000071

Fig.27 Template

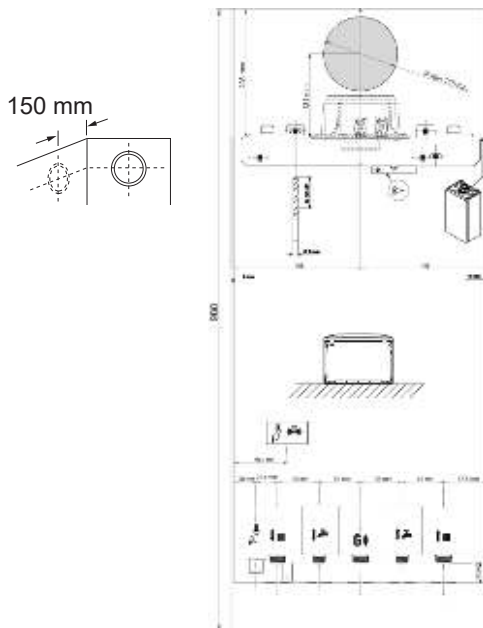

5.6.2 Initial preparation

1. After considering the site requirements position the fixing template on the wall ensuring it is level both horizontally and vertically.
2. Mark the position of the two most suitable fixing slots for the wall plate.
3. Mark the position of the centre of the flue hole (rear exit). For side flue exit, mark as shown.
4. If required, mark the position of the gas and water pipes. Remove the template.
5. Cut the hole for the flue (minimum diameter 116mm).
6. Drill the wall as previously marked to accept the wall plugs supplied. Secure the wall plate using the fixing screws.
7. Using a spirit level ensure that the plate is level before finally tightening the screws.

5.7 Connecting diagrams

5.7.1 Filling information

Fig.28 System filling circuit

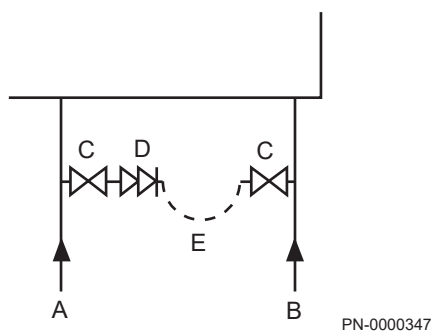

- A Domestic hot water mains inlet
- B Central heating return
- C Stop valve
- D Double check valve (Not supplied)
- E Loop (Temporary or Permanent)

A filling point connection on the central heating return pipework must be provided to facilitate initial filling and pressurising and also any subsequent water loss replacement/refilling.

The filling method adopted must be in accordance with all relevant water supply regulations and use approved equipment.

Your attention is drawn to:

for GB: Guidance G24.2 and recommendation R24.2 of the Water Regulations Guide.

for IE: the current edition of I.S. 813 Domestic Gas Installations.

- A Cold mains in
- B Heat return

The sealed primary circuits may be filled or replenished by means of a temporary connection between the circuit and a supply pipe, provided a "Listed" double check valve or some other no less effective backflow prevention device is permanently connected at the inlet to the circuit and the temporary connection is removed after use.

When the optional permanent filling link is fitted it is not necessary to remove any part of it after filling or re-pressurising.

Fig.29 Circuit plan

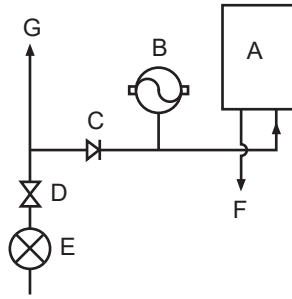

PN-0000350

5.7.2 Domestic hot water circuit

- A Boiler
- B Expansion vessel
- C Check valve
- D Pressure reducer
- E Stop tap
- F To hot tap
- G Other tap outlets

All DHW circuits, connections, fittings, etc. should be fully in accordance with relevant standards and water supply regulations.

Your attention is drawn to:

for GB: Guidance G17 to G24 and recommendation R17 to R24 of the Water Regulations Guide.

for IE: the current edition of IS 813 Domestic Gas Installations.

The Water Regulations recommendations for England and Wales prohibits backflow from appliances into the wholesome water supply due to thermal expansion. However this type of instantaneous combination boiler, with less than 15 litres of stored capacity, does not require any backflow prevention device as any thermal expansion is accommodated within the appliance. It is possible in certain circumstances that other cold water demands (e.g. washing machines, flushing of WCs) may affect the DHW function of the boiler. In these instances the fitting of a backflow prevention device and expansion vessel is recommended.

i Important

In instances where the mains water supply incorporates a non-return backflow prevention device, or any other device that includes one*, it is possible for a build-up of pressure to occur. This may result in damage to the boiler and other appliances. To prevent damage to the boiler it is strongly recommended that a suitable mini expansion vessel is fitted on the mains water inlet between the boiler and the non-return device.

*(The manufacturer of the device should be consulted if there is any doubt regarding the presence of a non-return feature).

Even in circumstances where a non-return device is not fitted any future modifications to the mains inlet (e.g. fitting of a water meter) should be considered and an expansion vessel fitted. Main cannot accept any responsibility for damage to the boiler if these recommendations are not followed.

The boiler's maximum working mains pressure is 8 bar, therefore all pipe-work, connections, fittings, etc. should be suitable for pressures in excess of 8 bar. A pressure reducing valve must be fitted for pressures in excess of 8 bar. The manufacturer of any outlet fittings, such as a shower valve, may require a lower maximum pressure. The pressure reduction must take account of all fittings connected to the DHW system.

6 Installation

6.1 General

Fig.30 Mounting the boiler

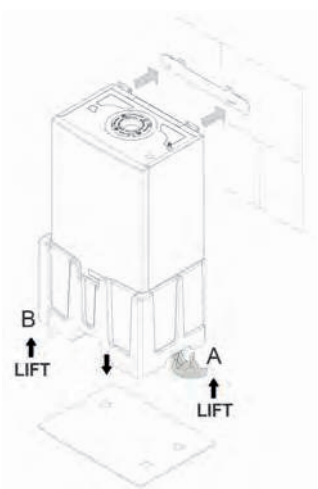
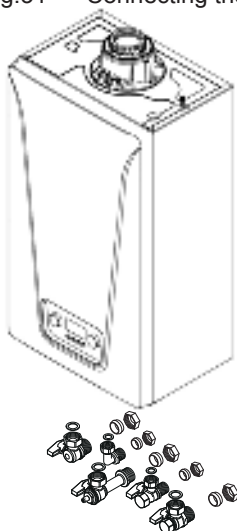

Fig.31 Connecting the taps



Installation must be carried out in accordance with the prevailing regulations, codes of practice and the recommendations in this manual.



Danger

If the boiler is installed in a compartment do not use it for storage purposes. Do not obstruct any purpose provided ventilation openings.



Caution

Where the boiler is sited in an unheated enclosure provision must be made to protect against frost, e.g. frost thermostat, pipe thermostat.

1. Lift the boiler by gripping "a" and "b" and hook the boiler onto the wall plate.
2. Remove the polystyrene bottom piece by slipping it off downwards.
3. Remove the sealing caps from the boiler connections under the boiler (including the condensate trap).



Warning

Some residual water may escape when removing the sealing caps. Take precautions to avoid damage to components !

4. Remove the taps, elbow and sealing washers from the fitting kit. The taps and elbow accept 15mm or 22mm copper pipe as appropriate — see template.
5. Connect the appropriate tap to the heating flow and return pipework, gas supply and mains cold inlet.
6. Connect the elbow to the DHW flow outlet.
7. Using the sealing washers provided connect the taps and elbow to the boiler.
8. Ensure all joints are tight.



Important

Connect the pressure relief discharge pipe first before any other pipework.

6.2 Assembly

6.2.1 Fitting the pressure relief discharge pipe

Fig.32 Pressure relief pipe connection

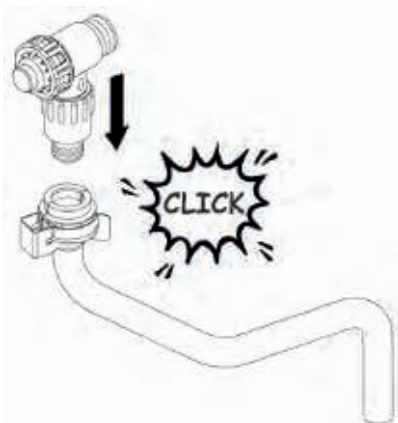

1. Remove the discharge pipe from the kit.
2. Determine the routing of the discharge pipe in the vicinity of the boiler. Make up as much of the pipework as is practical, including the discharge pipe supplied.



Important

Make all soldered joints before connecting to the pressure relief valve. Do not adjust the position of the valve. The discharge pipe must be installed before pressurising the system.

3. The pipework must be at least 15mm diameter and run continuously downwards to a discharge point outside the building.
4. Firmly engage the flange on the pipe into the pressure relief valve outlet grommet, ensuring it is pushed fully in.
5. Complete the discharge pipework and route it to the outside discharge point.

Fig.33 Pour 300ml of water into flue spigot

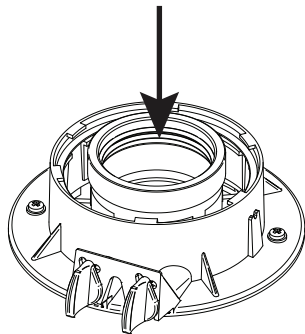

PN-0000602

- The pipework must be clipped at suitable intervals to support it, commencing as close to the boiler as possible.

6.2.2 Connecting the condensate drain

- Remove the blanking cap, and using the straight rubber coupling supplied, connect the condensate drain pipework to the boiler condensate trap outlet pipe.

**See**

Ensure the discharge of condensate complies with any national or local regulations in force (see HHIC recommendations).

**See**

Condensate drain, page 30.

- The straight rubber coupling will accept 21.5mm ($3/4$ in) plastic overflow pipe which should generally discharge internally into the household drainage system. If this is not possible, discharge into an outside drain is acceptable.

**Important**

The boiler condensate trap should be primed by pouring approximately 300ml of water into the flue spigot. Do not allow any water to fall into the air inlet.

6.3 Air supply/flue gas connections

Fig.34 Telescopic flue

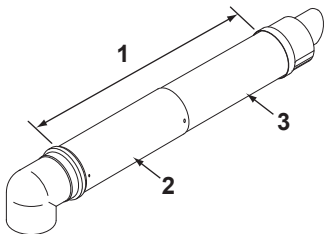

PN-0000462

6.3.1 Connecting the flue/chimney

HORIZONTAL TELESCOPIC FLUE (concentric 60/100)

- 315mm to 500mm
- Connection assembly
- Terminal assembly

There are two telescopic sections, the terminal assembly and the connection assembly, a roll of sealing tape and two self tapping screws. A 93° elbow is also supplied.

The two sections can be adjusted to provide a length between 315mm and 500mm when measured from the flue elbow (there is 40mm engagement into the elbow).

- Locate the flue elbow on the adaptor at the top of the boiler. Set the elbow to the required orientation.

**Important**

The flue elbow is angled at 93° to ensure a fall back to the boiler.

Fig.35 Flue dimension X

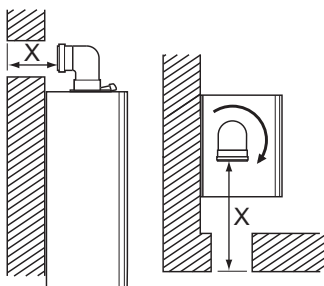

PN-0000463

- Measure the distance from the outside wall face to the elbow. This dimension will be known as "X".
- If the distance from the flue elbow to the outside face of the wall is less than 250mm the connection assembly can be discarded and the terminal assembly fitted directly into the elbow.
- In instances where the dimension "X" is between 250mm and 315mm it will be necessary to shorten the terminal assembly by careful cutting to accommodate walls of these thicknesses.

Fig.36 Flue dimension Y

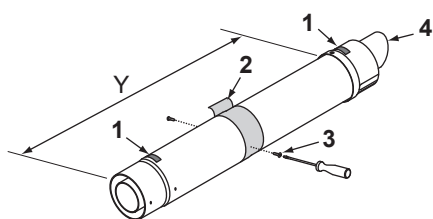

PN-0000464

Fig.37 Attaching the flue

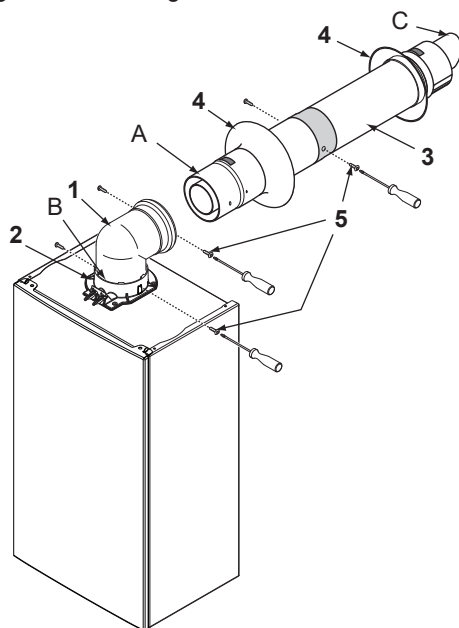

PN-0000465

5. To dimension "X" add 40mm. This dimension to be known as "Y".
 - 1 TOP label
 - 2 Sealing tape
 - 3 Securing screw
 - 4 Peak to be uppermost
6. Adjust the two telescopic sections to dimension "Y" and seal the joint with the tape provided. Ensure that the labels marked "TOP" on the terminal and connection assemblies are uppermost.
7. Using the clearance holes in the connection assembly secure it to the terminal assembly using the screws supplied with the telescopic flue.
8. Remove the flue elbow and insert the flue through the hole in the wall. Fit the flue trims if required, and refit the elbow to the boiler adaptor, ensuring that it is pushed fully in. Secure the elbow with the screws supplied in the boiler fitting kit.
 - 1 Flue elbow
 - 2 Boiler adaptor
 - 3 Telescopic flue
 - 4 Flue trim
 - 5 Securing screw
 - A Apply the lubricant supplied for ease of assembly (**do not use any other type**). Ensure flue is fully engaged into elbow.
 - B Apply the lubricant supplied for ease of assembly (**do not use any other type**). Ensure elbow is fully engaged into boiler adaptor.
 - C Peak to be uppermost
9. Draw the flue back through the wall and engage it in the elbow. It may be necessary to lubricate to ease assembly of the elbow and flue.
10. Ensure that the terminal is positioned with the slots to the bottom. Secure to the elbow with the screws supplied with the telescopic flue.

i Important

It is essential that the flue terminal is fitted as shown to ensure correct boiler operation and prevent water entering the flue.

11. Make good between the wall and air duct outside the building, appropriate to the wall construction and fire rating.
12. If necessary fit a terminal guard.

6.4 Electrical connections

The electrical safety of the equipment is only ensured when it is correctly connected to an effective earthing system in accordance with the prevailing safety standards for installations. The boiler must be electrically connected to a 230 V single phase + earth mains supply using the three-wire cable provided, respecting the Line-Neutral polarity.

**Caution**

This connection must be made using a two-pole switch with contact opening of at least 3 mm.

If the power supply cable must be replaced, a harmonised "HAR H05 VV-F" 3x0.75 mm² cable with a maximum diameter of 8 mm must be used.

**Warning**

Check that the total nominal consumption of the accessories connected to the appliance is less than 1 A. If it is higher, a relay must be installed between the accessories and the electronic board.

Fig.38 Accessing the circuit board

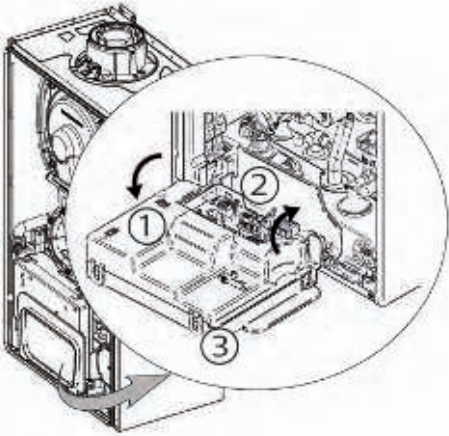

Fig.39 Adding wires to the PCB

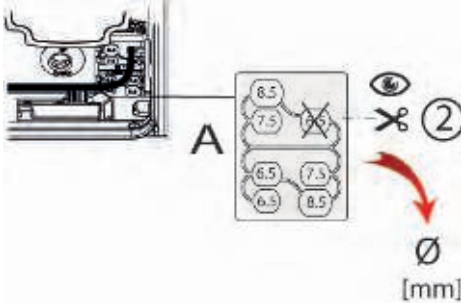

Fig.40 Connecting wires to the PCB

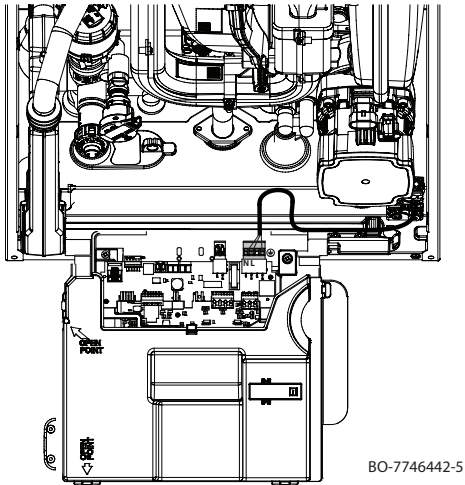
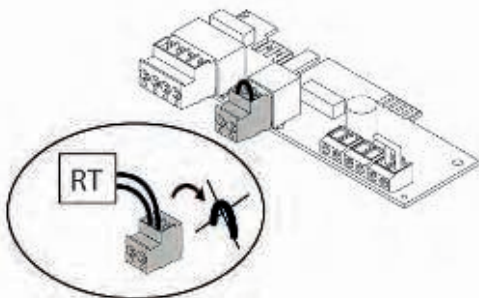

Fig.41 Connecting the room thermostat RT



6.4.1 Accessing the electrical connections



See

Section 10.3.1 Accessing the boiler components to remove the front cover

To access the electrical connection board:

- 1 Pull the control panel downwards (1).
- 2 Lift the rear cover (2).
- 3 Release the four catches to remove the cover (3) (do not use excessive force as this could break the plastic hooks).



Important

Do not use excessive force as this could break the plastic hooks.

To add one or more wires to the boiler wiring, proceed as follows:

- Undo the screw (1) on the multiple cable gland (A) located on the lower right-hand side of the boiler (the screw serves a cable gland);
- Determine the correct diameter for the cable gland, then cut the corresponding plug (2), as shown in the figure and feed the wire into the hole;
- Connect the wire then secure the cable gland in place by tightening the screw (1).
- The supply cable is connected to the terminal board as shown in the figure below.

L: 230 V (brown wire)

N: Neutral (blue cable)

⊕ : Earth connection:

6.4.2 Connecting the room thermostat

Before connecting the room thermostat (RT) or Open Therm (OT) device, remove the link wire on the terminal board as shown in figure 40.



Important

An ON/OFF room thermostat (also H.V. 230V) can be connected to the RT connector.

On the OT connector it is possible to connect a low voltage or Open therm, Rbus, room thermostat.

To use a H.V. thermostat remove the link between RT connector and maintain the link on the OT connector.

If you want to use an OT thermostat remove the link between OT connector and maintain the link on the RT connector.

6.4.3 Service connection (SERVICE)

Connect the wireless interface to terminal **X10** on the boiler PCB, as shown in the chapter entitled "Electrical diagram".

6.4.4 Connecting on wall outdoor sensor

The sensor must be fixed to an external wall surface of the property it is serving. The wall must face north or west. Under no circumstance must it be fixed to a south facing wall in direct sunlight.

The sensor must be positioned approximately at half the height of the living space of the property, and a minimum of at least 2.5 metres above ground level.

To ensure accurate operation do not position the sensor in the proximity of any heat or cooling source (e.g. a flue terminal). Siting above doors & windows, adjacent to vents and close to eaves should be avoided.

1. Once the position has been determined, prise the cover off the sensor and mark through the sensor body the two fixing holes and the larger hole for the wiring.
2. Drill & plug the two fixing holes (plugs and screws are supplied with the sensor). Also drill the hole for the sensor wiring.
3. Insert the sensor wiring through the hole in the wall, leaving sufficient length outside to allow connection. Seal the hole. **Note: 0.5mm 2 core cable is recommended** (the sensor is a low voltage device). This wiring is NOT supplied in the kit.
4. If it is not possible to pass the wiring through the wall directly behind, remove the circular 'knock-out' panel in the sensor base to allow connection.
5. Using the screws provided fit the body to the wall. Insert the wires in the two-way terminal block and secure them. Replace the sensor cover.
6. Ensure the electrical supply to the boiler is isolated and remove the front panel.
7. Hinge down the control box and unclip the terminal block cover.
8. Pass the wires from the sensor through one of the gland nuts in the bottom of the boiler lower panel, leaving sufficient slack to allow the control box to be hinged fully open. Tighten the nut.

Fig.42 Sensor position

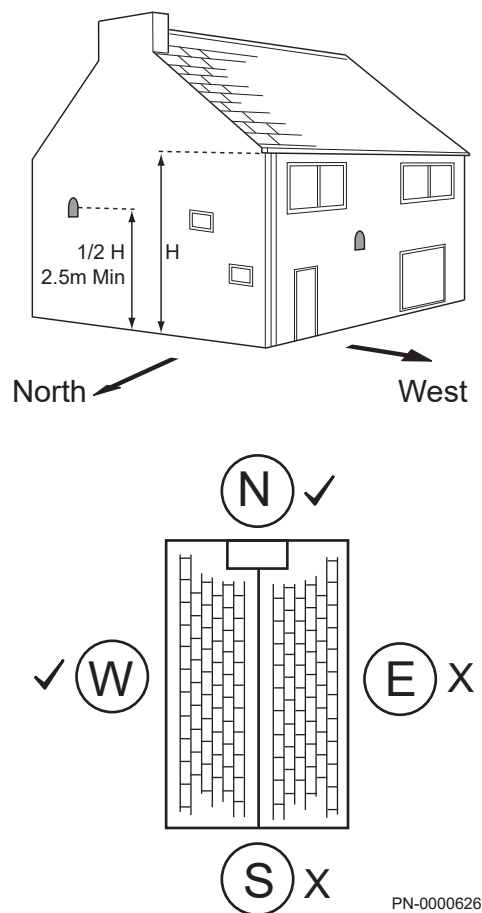
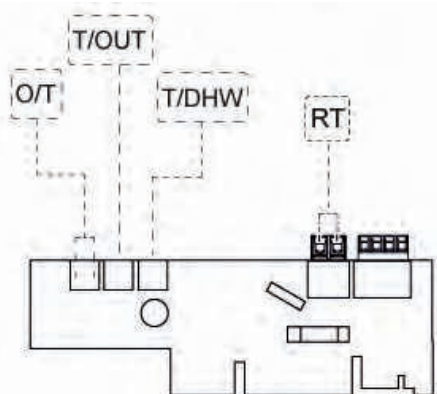

Fig.43 Connecting the outside sensor (OS)



6.4.5 Connecting the outside sensor

Connect the outside sensor to the T/OUT port on the connection board.

i Important
Set the type of outside sensor used by implementing setting AP056 (see table paragraph "List of installer settings").

6.4.6 Identifying label

i Important
The identifying label (7221476-01) supplied with the outdoor sensor must be signed and affixed on or adjacent to the boiler. The label must be readily accessible without removing the boiler casing or any other disassembly. This label is required to enable SAP and energy assessors to identify that a weather compensation device is installed and connected.

6.5 Filling the installation

Fig.44 Filling the installation

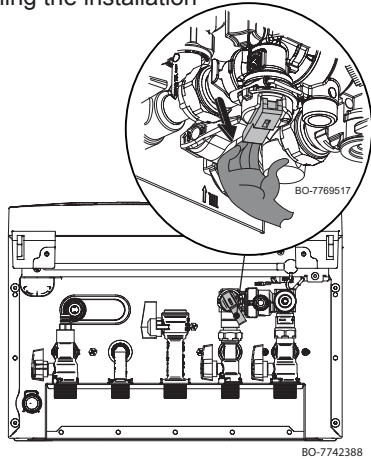

6.5.1 Flushing the system

Flush thoroughly and treat the system according to guidance given in BS 7593.

6.5.2 Fill the installation

A filling point connection on the central heating return pipework must be provided to facilitate initial filling and pressurising and also any subsequent water loss replacement/refilling.

1. Fill the installation using approved equipment and in accordance with all relevant water supply regulations.



Important

Your attention is drawn to:

for GB: Guidance G24.2 and recommendation R24.2 of the Water Regulations Guide.

for IE: the current edition of I.S. 813 "Domestic Gas Installations".

2. The sealed primary circuits may be filled or replenished by means of a temporary connection between the circuit and a supply pipe, provided a 'Listed' double check valve or some other no less effective backflow prevention device is permanently connected at the inlet to the circuit and the temporary connection is removed after use.
3. Fill or replenish the sealed primary circuits by means of a temporary connection between the circuit and a supply pipe:
 - Permanently connect a 'Listed' double check valve or some other no less effective backflow prevention device at the inlet to the circuit.
 - Remove the temporary connection after use except if where a permanent connection is used.

6.5.3 Filling the condensate trap

1. Check that the boiler condensate trap has been primed before commissioning the boiler.

6.6 Draining the installation

Fig.45 Draining the installation

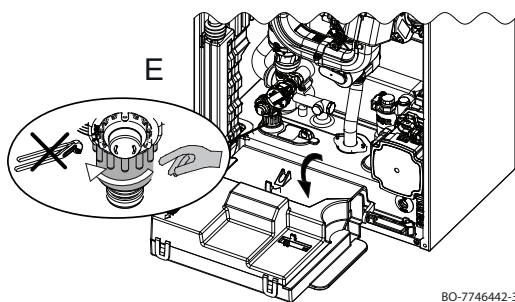

The drain cock is inside the boiler (in the lower left-hand section). To access the cock and drain it, proceed as follows:

1. Remove the front panel from the boiler and turn the control panel downwards, as shown in the adjacent figure.
2. Slowly open the cock (E) anti-clockwise to drain the boiler and the system. Do not use tools.
3. Close the cock by turning it clockwise, without using excessive force.

7 Commissioning

7.1 General

Commissioning the boiler is done for first time use, after a prolonged shut-down (more than 28 days) or after any event that would require complete re-installation of the boiler. Commissioning of the boiler allows the user to review the various settings and checks to be made to start up the boiler in complete safety.

7.2 Checklist before commissioning

Perform the following checks before commissioning the boiler:

1. Check that the gas type supplied matches the data shown on the boiler's data plate.



Danger

Do not commission the boiler if the gas supplied does not match the gas types approved for the boiler.

2. Check the connection of the earthing cable.
3. Check the gas circuit from the non-return valve to the burner.
4. Check the hydraulic circuit from the boiler's isolation valves to the heating circuit.
5. Check that the hydraulic pressure in the heating installation is between 1.0 and 1.5 bar.
6. Check the power supply connections to the various boiler components.
7. Check the electrical connections on the thermostat and the other external components.
8. Check the ventilation in the room in which the system is installed.
9. Check the flue gas connections.

7.3 Commissioning procedure

Proceed as described below to commission the boiler:

Open the main gas cock.

Open the gas cock on the boiler.

Open the front panel as described in the chapter entitled "Accessing the boiler electrical connection board".

Check the gas supply pressure at the pressure socket on the gas valve.

Check the leak tightness of the gas connections in the boiler upstream of the gas valve.

Check the tightness of the gas pipe, including the gas valves. The test pressure must not exceed 60 mbar (6 kPa).

Degas the gas supply pipe by unscrewing the pressure socket on the gas valve. Reclose the socket once the pipe has been sufficiently bled.

Check that the siphon is full of water as described in the chapter entitled "Filling the siphon".

Check that there are no leaks in the hydraulic connections.

Check the seal/condition of the flue gas pipes.

Use the two-pole switch to supply voltage to the boiler.



Important

For instructions on igniting the boiler, see the following chapter entitled "Procedure for first start-up".

7.4 Gas settings

Fig.46 Gas meter to valve

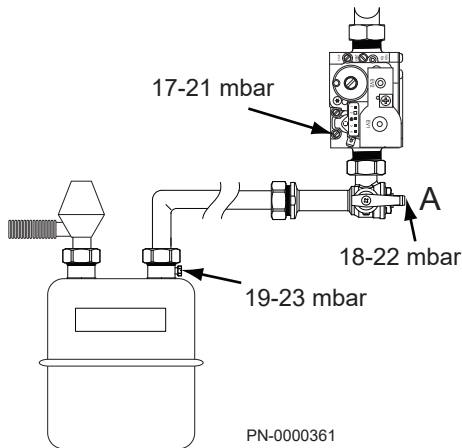

Fig.47 Gas inlet test point

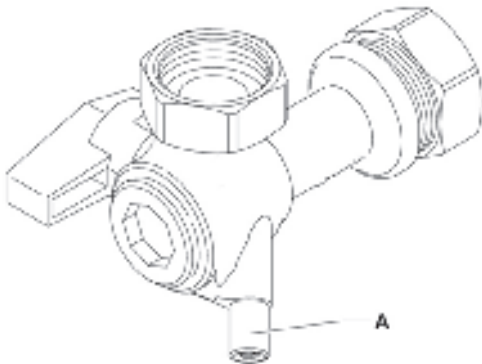
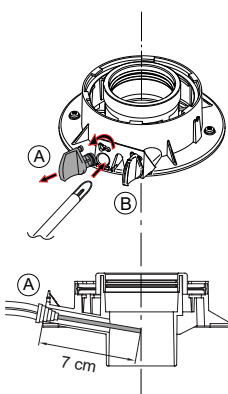

Fig.48 Type of fittings — flue gas measuring point



7.4.1 Check the operational (working gas inlet pressure and gas rate)

i Note
If the pressure drops are greater than shown in the diagram opposite, a problem with the pipework or connections is indicated. Permissible pressure drop across system pipework ≤ 1 mbar. Carry out chimney sweep.

See
Checking combustion - chimney sweep mode, page 49.

1. With the boiler operating in the maximum rate condition check that the operational (working) gas pressure at the inlet gas pressure test point is in accordance with BS 6798 & BS 6891. This must be AT LEAST 18mb !
2. Ensure that this inlet pressure can be obtained with all other gas appliances in the property working. The pressure should be measured at the gas test point on the gas inlet (A).
3. **Measure the gas rate** — With any other appliances & pilot lights turned OFF the gas rate can be measured. The gas rate can be found in section 3. Technical specifications.

7.4.2 Combustion parameters

The boiler has two dedicated sockets in order to measure the combustion efficiency and cleanliness of the combustion exhaust gases during operation. One socket is connected to the flue gas exhaust circuit (A) which is used to detect the cleanliness of the combustion exhaust gases and the combustion efficiency. The other is connected to the combustion air intake circuit (B) which is used to check for the possible recirculation of the combustion exhaust gases in the case of coaxial pipes. The following parameters can be measured when using the socket connected to the flue gas circuit:

- temperature of the combustion exhaust gases;
- concentration of oxygen O_2 or alternatively carbon dioxide CO_2 ;
- concentration of carbon monoxide CO .

The temperature of the combustion air must be measured using the socket connected to the air intake circuit (B), inserting the measurement probe approx. 7 cm.

In order to analyse the combustion exhaust gases, the chimney sweep function must be activated, as described below.

Fig.49 Examples of combustion checks

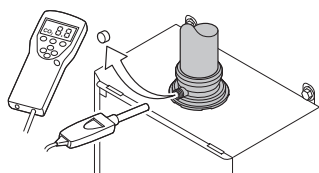
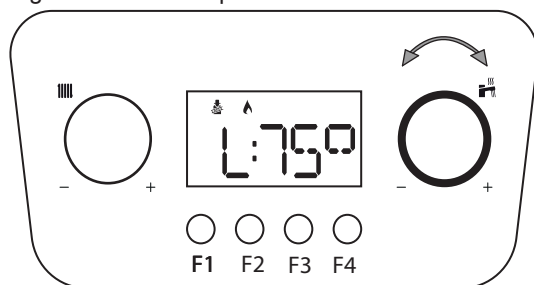
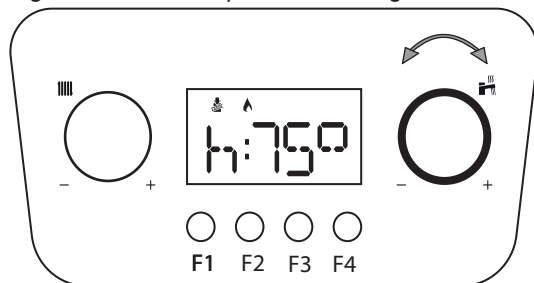

Fig.50 Minimum power



BO-0000230-1

Fig.51 Maximum power in heating mode



BO-0000230-2

Fig.52 Maximum power in domestic water mode

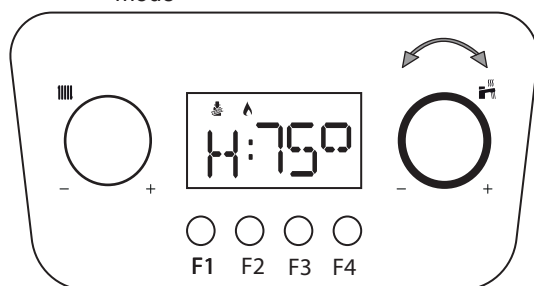



BO-0000230-3

**Caution**

To analyse the products of combustion, ensure adequate heat exchange in the system in heating mode or in domestic water mode (by opening one or more domestic hot water cocks) to avoid the boiler shutting down as a result of overheating. For correct boiler operation, the CO₂ (O₂) content in the combustion gases must be within the tolerance range indicated in the table below.

■ Activating the chimney sweep function

1. Press the two **F1 + F2** keys until the function activates. When the letter **L** appears on the display (followed by the flow temperature) the boiler is working at minimum power.
2. Turn the  knob one notch to the right. When the letter **h** appears on the display (followed by the flow temperature) the boiler is working at maximum power in HEATING MODE.
3. Turn the  knob another notch to the right. When the letter **H** appears on the display (followed by the flow temperature) the boiler is working at maximum power in DOMESTIC WATER MODE.

**Important**

This function is carried out in heating mode. During this function, for LOW TEMPERATURE systems (such as underfloor heating), the flow temperature is limited by setting **CP000** (maximum flow temperature).

To activate the domestic water mode, configure the setting to **GP082=1** Once finished, return the setting to **GP082=0**
 ⇨ To finish and exit the function press the **F1** key.

**Caution**





Remember to return the setting to **GP082=0** once the chimney sweep function is no longer in use.

**Warning**

Ensure that both flue test point plugs are in place after checking combustion.

7.4.3 Service settings

Tab.24 CO – CO₂ – O₂ values with the front panel CLOSED

	Fan parameters - rpm						Front panel closed				
	224 combi 2		Pmin 224 combi 2	228 combi 2		Pmin 228 combi 2	CO ₂ % Nominal & range of tolerance		CO max	O ₂ % Nominal & range of tolerance	
	DP003*	GP007*	GP008*	DP003*	GP007*	GP008*	@Pn Max	@Pmin	ppm	@Pn Max	@Pmin
	24 kW	20 kW	4,8 kW	28 kW	20 kW	5,9 kW					
			-			-					
G20 *	9300	8100	2900	8600	6450	2800	9,0% (8,8 ÷ 9,4)	8,5% (8,1 ÷ 8,6)	<250	4,8% (5,2 ÷ 4,1)	5,7% (6,5 ÷ 5,6)
G31	8900	7700	2900	-	-	-	10,3% (10,2 ÷ 10,7)	9,7% (9,2 ÷ 9,8)	<350	5,2% (5,4 ÷ 4,6)	6,1% (6,9 ÷ 6,0)

* When using mixes that are up to 20% hydrogen (H₂), for calibrating the gas valve only refer to the value of O₂%.

**Important**

This appliance is suitable for G20 gas containing up to 20% hydrogen (H₂). Due to variations in the percentage of H₂, the percentage of O₂ may vary over time. (For example: 20% of H₂ in the gas may lead to a 1.5% increase of O₂ in the flue gases) The gas valve may need to be adjusted more accurately. This must be adjusted using standard O₂ values for the gas used.

Fig.53 Gas valve

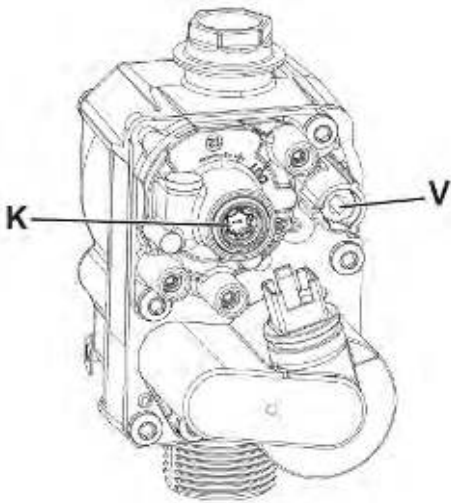

7.4.4 Calibrating the gas valve

- V Gas flow rate setting screw - 4mm Allen key
 K OFFSET setting screw - Torx 40 (T40)

Remove the boiler door to take measurements or make adjustments.

- Calibration of the MAXIMUM heat input
 Check that the CO₂ measured in the exhaust pipe, with the boiler operating at maximum heat input, is as indicated in the table entitled "Service settings".
- If incorrect:
 Put the boiler into chimney sweep high mode "H". Let the CO₂ value stabilise.



Important

Remove the Allen key to stabilise the CO₂ value if adjustment is required.

- Adjust the setting screw (V) located on the gas valve. Turn the screw clockwise to increase the content of CO₂ and anti-clockwise to decrease it.

Baxi Combi		24 Combi (C) - 28 Combi (C)
CO ₂ *	% (maximum)	8.8 to 9.4

* Values for G20 gas type only. For G20+20%H₂ calibration of the gas valve refer to O₂%.

Calibration of the REDUCED heat input

- Check that the measurement in the exhaust pipe, with the boiler operating at minimum heat input, is as indicated in the table entitled "Service settings".

If incorrect:

Remove the Offset setting screw plug (K) using the Torx driver.

- The Offset setting screw is accessible after removing the Offset setting screw plug (K).
 Put the boiler into chimney sweep low mode. Let the CO₂ value stabilise.



Important

Remove the Torx driver to stabilise the CO₂ value if adjustment is required.

- Adjust the Offset setting screw located on the gas valve. Turn the screw clockwise to increase the content of CO₂ and anti-clockwise to decrease it.

Baxi Combi		24 Combi (C) - 28 Combi (C)
CO ₂	% (minimum)	8.1 to 8.6

* Values for G20 gas type only. For G20+20%H₂ calibration of the gas valve refer to O₂%.

Fig.54 Combustion procedure

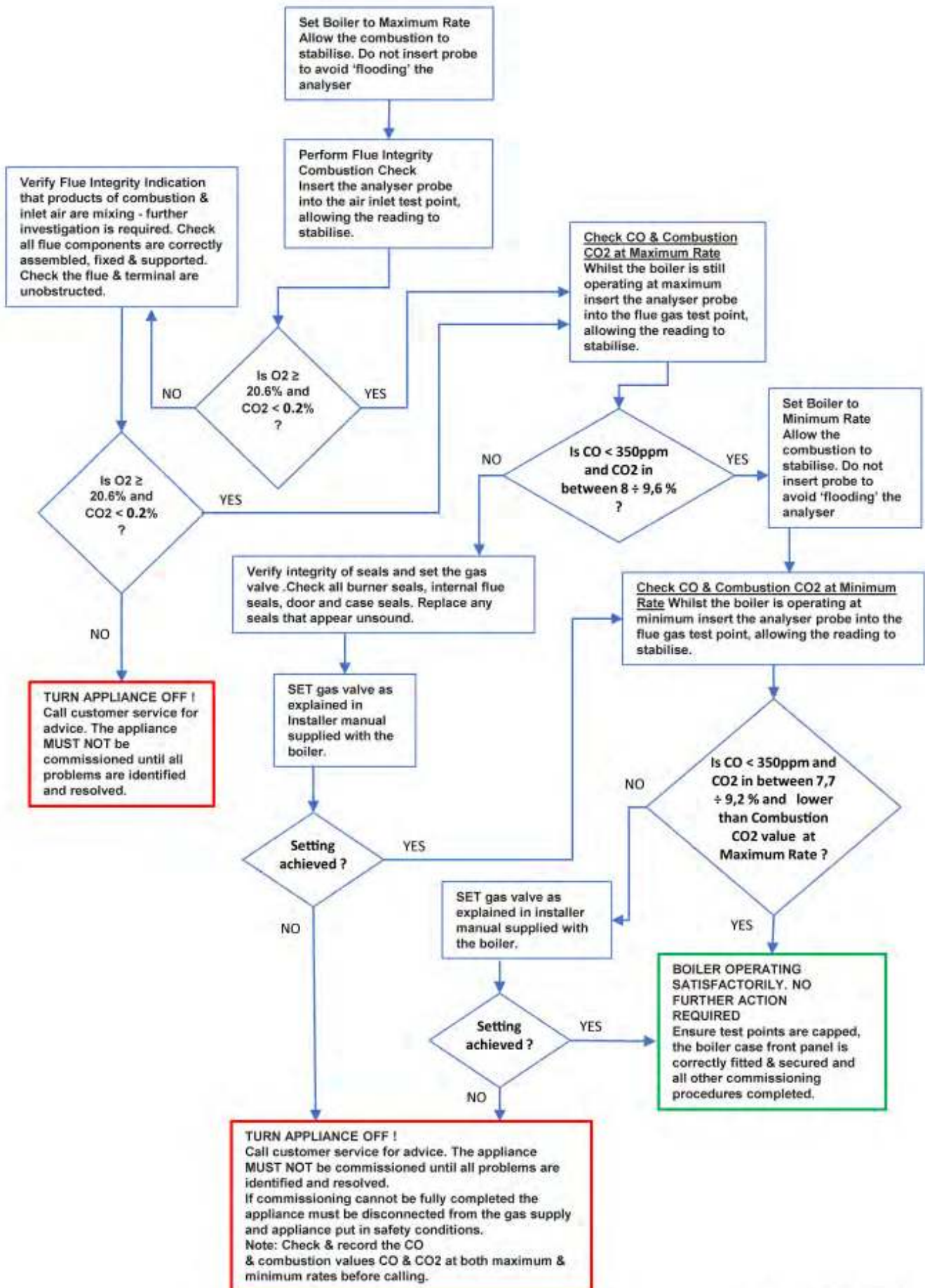

7.5 Final instructions

Fig.55 People

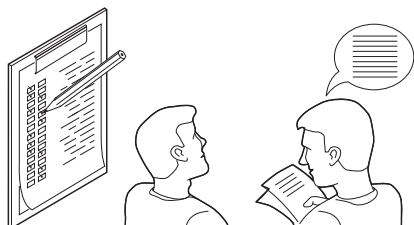

PN-0000333

7.5.1 Handover

1. Carefully read and complete all sections of the Benchmark Commissioning Checklist at the rear of this publication that are relevant to the boiler and installation. These details will be required in the event of any warranty work.



Important

The warranty will be invalidated if the Benchmark section is incomplete.

2. The publication must be handed to the user for safe keeping and each subsequent regular service visit recorded.
3. Hand over the User's Operating, Installation and Servicing Instructions, giving advice on the necessity of regular servicing.
4. **For IE**, it is necessary to complete a "Declaration of Conformity" to indicate compliance with I.S. 813. An example of this is given in I.S. 813 "Domestic Gas Installations". This is in addition to the Benchmark Commissioning Checklist.
5. Set the central heating and hot water temperatures to the requirements of the user. Instruct the user in the operation of the boiler and system.
6. Instruct the user in the operation of the boiler controls.
7. Demonstrate to the user the action required if a gas leak occurs or is suspected. Show them how to turn off the gas supply at the meter control, and advise them not to operate electric light or power switched, and to ventilate the property.
8. Show the user the location of the system control isolation switch, and demonstrate its operation.
9. Advise the user that they may observe a plume of vapour from the flue terminal, and that it is part of the normal operation of the boiler.

8 Operation

8.1 Use of the control panel

Fig.56 Accessing the menu

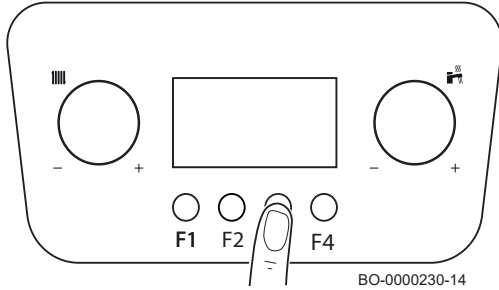

Fig.57 Scrolling through the menus and/or settings

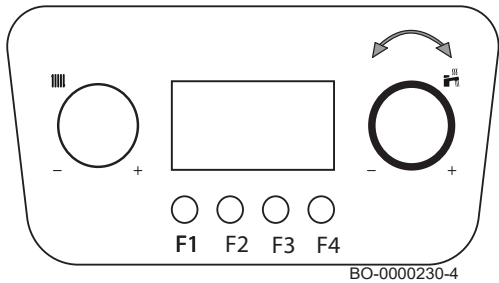

Fig.58 Scrolling through the values

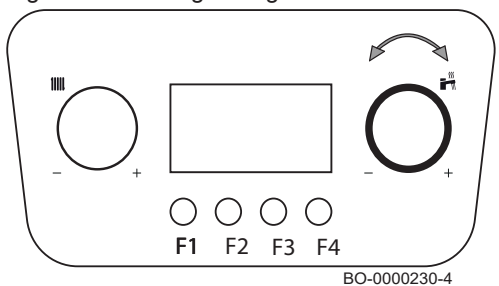
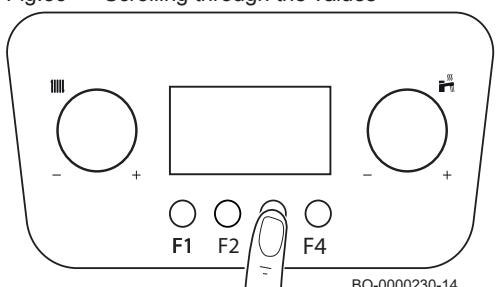

Fig.59 Scrolling through the values



8.1.1 Browsing the menus

1. To activate the control unit, press any button.
2. To access the settings available from the menu, press the **F3** key.

Tab.25 Available menu options

	Information menu
	User menu
	Installer menu
	Error menu
	Counter menu

3. Turn the knob to select the menu or to scroll through the settings.
4. Press the **F4** key to confirm selection of the required menu.
5. Turn the knob to scroll through the list of settings. Press the **F4** key to confirm selection of the setting.
6. Turn the knob to modify the setting. Press the **F4** key to confirm the setting has been changed.
7. Press the **F1** key to return to the home screen.



Important

The display shows the home screen if no keys are pressed for two minutes. If this happens, the procedure needs to be repeated.

8.1.2 Running the automatic detection function

After removing or replacing a PCB accessory board (not main PCB), an auto-detect must be carried out.

1. Select the installer menu and type in the password to enter
2. Turn the knob until **AD** is displayed
3. Press the **F4** button and **-AD-** appears on the display
4. Press the **F4** knob again to activate the function

8.1.3 Information menu display

1. Navigate to the Information menu .
2. Press the **F4** key to open the menu.
3. Turn the knob to scroll through the values.
4. Press the **F1** key several times to go back to the home screen.

8.1.4 Counter menu display

1. Navigate to the Counter menu.
2. Press the **F4** key to open the menu.
3. Turn the knob to scroll through the values.
4. Press the **F1** key several times to go back to the home screen.

8.2 Start-up

8.2.1 Procedure for first start-up

The following information appears on the display when the boiler is electrically powered:

1. The message "INIT" appears, indicating that the "Initialisation" phase is active (a few seconds);
2. The software version "Vxx.xx." appears (two seconds);
3. The software version for boiler settings "Pxx.xx." appears (two seconds);
4. The boiler and heating installation venting phase has started. During operation, the display shows in alternate mode "-----", the word "DEAIR" and the pressure value for the heating circuit. This phase lasts 6 minutes and 20 seconds, at the end the boiler is ready for operation;
5. The  symbol and the "x.x" installation water pressure value appear.

In the event of a power outage the procedure will be repeated from the beginning.

To activate a heating request, the room thermostat must be set to a temperature above the current temperature (or open a domestic water tap.)

8.2.2 Changing the heating flow temperature

1. Use the knob  to adjust the flow temperature in heating mode.
 - Turn the knob anti-clockwise to reduce the temperature value. Turn the knob clockwise to increase the temperature value.

i Important
With an outside sensor connected it is possible to lower the setpoint value.

2. Press the **F4** key to confirm the value or wait a few seconds until the value is automatically saved.

i Important
The flow temperature is matched automatically when using a:

- Weather-dependent regulator.
- **OpenTherm** regulator.

8.2.3 Changing the domestic hot water (DHW) temperature

1. Use the  knob to adjust the domestic hot water temperature.
 - Turn the knob anti-clockwise to reduce the temperature value.
 - Turn the knob clockwise to increase the temperature value.
2. Press the **F4** key to confirm the value or wait a few seconds until the value is automatically saved.

Fig.60 Scrolling through the menus and/or settings

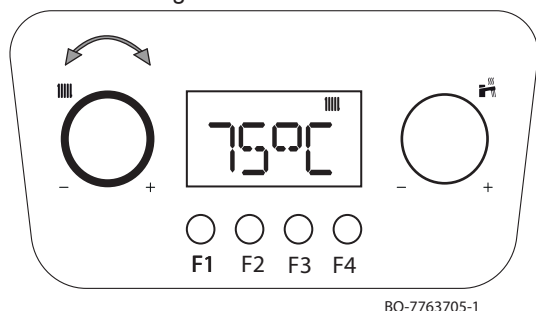
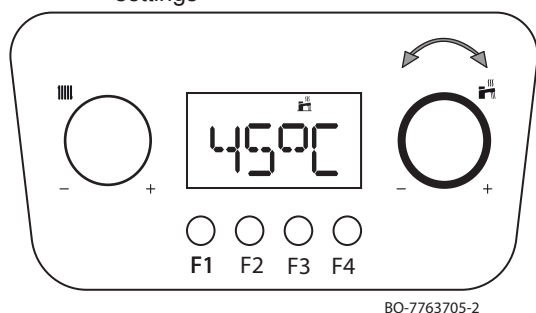



Fig.61 Scrolling through the menus and/or settings



8.3 Shutdown

8.3.1 Switching off the heating and domestic hot water (DHW)

Heating mode can also be disabled by turning the  knob anti-clockwise until the word **OFF** appears on the display.

i **Important**
When heating mode is re-enabled check, by turning the knob, that the comfort temperature is that requested.

i **Important**
Heating is disabled but the frost protection function remains activated.

Domestic hot water mode can also be disabled by turning the  knob anti-clockwise until the word **OFF** appears on the display.

To switch the boiler off completely, switch off the power supply to the appliance and close the gas cock.

i **Important**
In this condition, the boiler and the heating installation are not protected against frost.

8.4 Degassing function

The purpose of this function is to degas the heating installation. After installing the boiler, the function activates immediately when the boiler is first started up. The function automatically activates each time the boiler power supply is turned off and then on again.

To start the function manually:

- Access the installer menu and enter the password.
- Turn the  knob until **"DEAIR"** is displayed.
- Press the **F4** knob and **-AIR-** appears on the display
- Press the **F4** knob again to activate the function.

8.5 Frost protection

It is a good idea to prevent the heating installation from draining completely, as changing the water can result in unnecessary and damaging limescale deposits from forming inside the boiler and heating elements. If the thermal installation is not intended to be used during the winter months and there is a risk of frost, we recommend mixing suitable antifreeze solutions designed for a specific purpose (e.g. propylene glycol, which contains limescale and corrosion inhibitors) into the water in the installation. The boiler's electronic control system is equipped with an "antifreeze" function for the heating system. This function activates the boiler pump when the heating system flow temperature falls below 7 °C. If the water temperature reaches 4 °C, the burner is switched on, bringing the system water to a temperature of 10 °C. When this value is reached the burner switches off and the pump continues to operate for another 3 minutes.

i **Important**
The frost protection function will not work if there is no power being supplied to the boiler or if the gas supply cock is closed.

9 Settings

9.1 Accessing the settings

Fig.62 Step 2

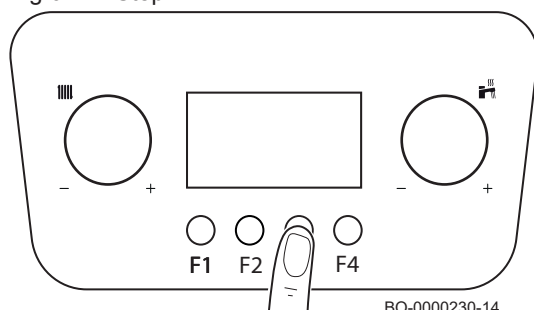





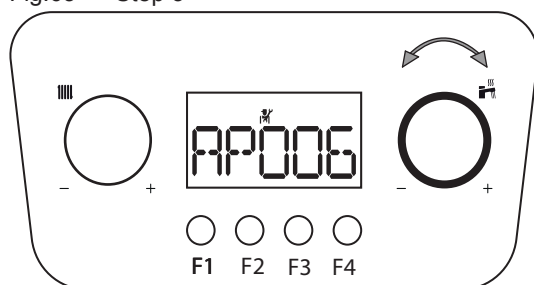

BO-0000230-14

Fig.63 Step 3



BO-0000230-9

To display/change the list of SERVICE settings, proceed as follows:

- press the **F3** key, the  symbol on the menu bar starts to flash;
- turn the  knob until you reach the  symbol to access user settings, turn until you reach the  symbol to access installer settings, then press the **F4** key to confirm;
- if accessing the installer menu, use the  knob to enter code **0012** and confirm by pressing the **F4** key
- turn the  knob until you reach the desired setting, then press the **F4** key to confirm;

- modify the value of the setting using the  knob;
- press **F4** to confirm;
- press **F1** to exit.

To view/modify the list of settings, it is also possible to connect the Bluetooth interface to the boiler via the connector **X10**. Then interface the handset (SERVICE) to the boiler using the **SERVICE TOOL** software.



Danger

FOR LOW TEMPERATURE HEATING INSTALLATIONS
MODIFY SETTING CP000 ACCORDING TO THE MAXIMUM
FLOW TEMPERATURE.



Important

The factory settings for certain settings may differ based on the market the product is destined for.

9.2 List of parameters

Tab.26 Table of parameters

Name	Description	Factory value	Minimum	Maximum	Level
AP001	Operation of contact X15 (also see setting AP098) 1: Contact open → Heating, domestic hot water and antifreeze disabled (error code H02.10) 2: Contact open → Heating, domestic hot water disabled (error code H02.09) 3: Contact open → Heating, domestic hot water and antifreeze disabled (error code E02.13 with reset request)	2	–	–	Installer
AP002	Manual heating request enabled based on implementation of setting AP026 0: Disabled 1: Enabled	0	–	–	Installer
AP006	Notification of low pressure in the heating installation [bar]	0.8	0.6	3.0	Installer
AP009	Hours of burner ignition before the maintenance notification with AP010=1	3000	0	51,000	Installer
AP010	Enables/disables maintenance notifications: 0: No notification 1: Customised notification (depending on settings AP009 and AP011)	0	–	–	Installer

Name	Description	Factory value	Minimum	Maximum	Level
AP011	Hours of electric boiler ignition before the maintenance notification with AP010=1	17500	0	51,000	Installer
AP016	CH operation 0: Off 1: On	1	–	–	User
AP017	Domestic hot water (DHW) 0: Off 1: On	1	–	–	User
AP026	Flow temperature setpoint [°C] for manual heat request with AP002=1	40	10	90	Installer
AP056	Outside sensor 0: No outside sensor 1: AF60 2: QAC34	2	–	–	Installer
AP063	Maximum temperature setpoint [°C] in heating and domestic water mode	80	25	90	Installer
AP073	Average external temperature [°C] when switching from summer/winter mode (with outside sensor)	22	10	30	User
AP074	Force summer mode (with outdoor sensor). Sanitary (DHW) enabled and heating disabled. 0: Auto according to AP073 1: Summer	0	–	–	User
AP079	Building insulation level (with outside sensor) 0: Poorly insulated building 15: Well insulated building	3	0	15	Installer
AP080	External temperature [°C] below that at which anti-frost protection is activated	-10	-30	+25	Installer
AP082	Not used	0	–	–	Installer
AP091	Type of outdoor sensor used: 0: Auto 1: Wired sensor 2: Wireless sensor 3: Internet measured 4: None	0	–	–	Installer
AP098	Configuration of boiler blocking input contact X15 (also see setting AP001) 0: Normally open 1: Normally closed	1	0	1	Installer
AP101	Type of degassing 0: Disabled 1: Auto (every time the power supply is restored) 2: Enabled (during the first commissioning only)	1	–	–	Installer
CP000	Max. settable heating setpoint temperature [°C]	80	25	80	Installer
CP020	Zone function 0: Disabled 1: Enabled	1	–	–	Installer
CP210	Comfort mode heating curve offset (with outside sensor)	15	15	90	Installer
CP230	Heating curve slope (with outside sensor)	1.5	0	4	Installer
CP470	Number of days required for the screed drying program	0	0	30	Installer
CP480	Screed drying starting temperature [°C]	20	20	50	Installer
CP490	Screed drying stop temperature [°C]	20	20	50	Installer
CP780	Zone control strategy selection 0: Automatic 1: Room Temp. based 2: Outdoor Temp. based 3: Outdoor & room based	0	–	–	Installer

Name	Description	Factory value	Minimum	Maximum	Level
DP003	Maximum fan speed in domestic hot water mode [rpm]	See chapter "Service Settings"	–	–	Installer
DP004	Anti-legionella function 0: Disabled 1: Weekly 2: Daily (only available with Room Unit)	0	–	–	User
DP005	Difference between the flow temperature and the temperature requested by the calorifier tank [°C]	15	0	25	Installer
DP006	Difference between the temperature detected by the calorifier tank sensor and the desired DHW temperature that enables a heat request [°C]	4	2	15	Installer
DP007	Position of three-way valve in standby 0: CH operation 1: DHW (Domestic Hot Water)	1	–	–	Installer
DP034	Corrects in a negative sense the value measured by the calorifier tank sensor [°C]	0	0	10	Installer
DP070	Domestic hot water temperature setpoint. In the case of operation with a calorifier tank and programming via room unit corresponding to the comfort setpoint [°C] * Depends on the marke	(55/60) *	35	(60/65) *	User
DP150	Enabling the calorifier tank sensor/thermostat 0: DHW (Domestic Hot Water) sensor 1: DHW (Domestic Hot Water) thermostat	1	–	–	Installer
DP160	Temperature setpoint of the anti-legionella function [°C]	65	60	90	Installer
DP200	DHW mode: 0: Domestic hot water programming (only available with Room Unit) 1: Manual (boiler with calorifier tank) – Preheating active (instantaneous boiler) 2: Antifreeze (boiler with calorifier tank) – No preheating (instantaneous boiler)	2	–	–	User
DP410	Duration of the DHW anti-legionella program [minutes]	3	0	600	Installer
DP420	Maximum anti-legionella duration time [minutes]	15	0	360	Installer
DP430	Day to start the DHW anti-legionella program [day] 1: Monday 2: Tuesday 3: Wednesday 4: Thursday 5: Friday 6: Saturday 7: Sunday	1	1	7	Installer
DP440	Starting time for the DHW anti-legionella program [minutes]	30	0	143	Installer
GP007	Maximum fan speed in heating mode [rpm]	See chapter "Service Settings"	–	–	Installer
GP008	Minimum fan speed [rpm]	See chapter "Service Settings"	–	–	Installer
GP009	Fan starting speed [rpm]	4300	2500	6000	Installer
GP082	Enabling domestic water circuit during chimney sweep function	0	0	1	Installer
PP015	Pump post circulation run time after heating mode request [min]	3	0	99	Installer
PP016	Maximum pump speed in heating mode [%]	100	80	100	Installer

Name	Description	Factory value	Minimum	Maximum	Level
PP018	Minimum pump speed in heating mode [%]	85	80	100	Installer
DEAIR	Manual degassing function	–	–	–	Installer
CNF	Configuration CN1 and CN2	--	–	–	Installer
AD	Searching for devices connected to the boiler PCB	--	–	–	Installer

Tab.27 Settings table with eMO Life

Name	Description	Factory value	Minimum	Maximum	Level
CP060	Required ambient temperature (°C) in the zone in the holiday/antifreeze period	6	5	20	User
CP070	Maximum ambient setpoint temperature (°C) in reduced mode that enables switching to comfort mode with climate control (with outside sensor)	16	5	30	User
CP080	Temperature (°C) set by SLEEP activity in the zone	16	5	30	User
CP081	Temperature (°C) set by HOME activity in the zone	20	5	30	User
CP082	Temperature (°C) set by AWAY activity in the zone	6	5	30	User
CP083	Temperature (°C) set by MORNING activity in the zone	21	5	30	User
CP084	Temperature (°C) set by EVENING activity in the zone	22	5	30	User
CP085	Temperature (°C) set by CUSTOM activity in the zone	20	5	30	User
CP200	Required ambient temperature (°C) for the zone in manual mode	20	5	30	User
CP220	Reduced mode heating curve offset (with outside sensor).	15	15	90	Installer
CP240	Adjust the effect of the room unit compared to the outside sensor	3	0	10	Installer
CP250	Correct the temperature measured by the room unit	0	-5	+5	User
CP320	Zone operating mode 0: Scheduling 1: Manual 2: Off	0	–	–	User
CP510	Temporary room setpoint per zone	20	5	30	User
CP550	Fireplace mode 0: Disabled 1: Enabled	0	–	–	User
CP570	Timer programme selected by User 0: Program 1 1: Program 2 2: Program 3	0	–	–	User
CP730	Boost when starting zone heating: Modify the heating curve to speed up or slow down reaching of the required comfort environment 0: Extremely slowly 1: More slowly 2: Slowly 3: Normal 4: Quickly 5: Extremely quickly	3	–	–	Installer
CP740	Building cooling speed when the heating is turned off 0: Extremely slowly 1: Slowly 2: Normal 3: Quickly 4: Extremely quickly	2	–	–	Installer

Name	Description	Factory value	Minimum	Maximum	Level
CP750	Maximum preheating time [min] to reach the next programmed comfort setpoint (with outside sensor and programming via room unit)	0	0	240	Installer
DP060	Timer programme selected for DHW 0: Program 1 1: Program 2 2: Program 3	0	–	–	User
DP080	Reduced temperature setpoint for the domestic hot water tank [°C]	35	10	60	User
DP337	Domestic hot water temperature setpoint for the holiday period [°C]	10	10	60	User

**Danger**

For low temperature heating installations, modify the **CP000** parameter according to the maximum flow temperature.

The factory settings for certain settings may differ based on the market the product is destined for.

9.2.1 Resetting factory settings

To reset the factory settings, modify the **CN1** and **CN2** settings with the data on the boiler data plate.

**Caution**

Please note that resetting the **CN1** and **CN2** settings with data on the data plate deletes any previous setting.

In case of gas change, for example, remember to set the correct calibration of the gas valve and the fan speed.

9.3 Setting the parameters

Fig.64 Outside sensor connection

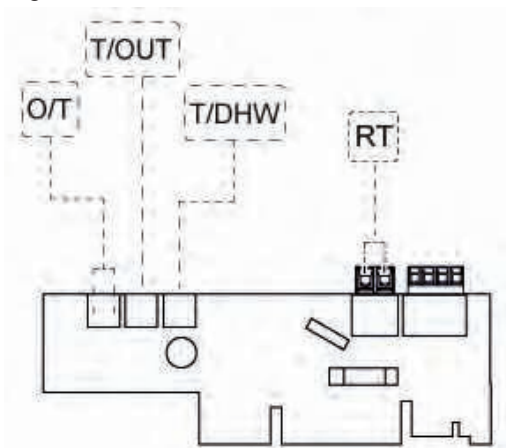

9.3.1 Setting the heating curve

Remove the jumpers. Connect the outside sensor to the T/OUT port on the connection board. Connect the "On/Off" type room thermostat or the "Open Therm" type room unit to the O/T port on the connection board.

**Important**

An ON/OFF room thermostat (also H.V. 230V) can be connected to the RT connector.

On the OT connector it is possible to connect a low voltage or Open therm, Rbus, room thermostat.

To use a H.V. thermostat remove the link between RT connector and maintain the link on the OT connector.

If you want to use an OT thermostat remove the link between OT connector and maintain the link on the RT connector.

**Important**

If the heat curve is set via an OpenTherm room unit, do not set the heat curve with these parameters.

**See**

9.1 Accessing the settings to access the heating curve setting.

To set the curve, change the following settings:

- CP000: Heating flow maximum temperature set point.
- CP200: room temperature setpoint for zones 5.0 to 30.
- CP210: comfort mode climatic curve offset from 15 to 90 (with external probe). Do not change the slope of the curve.
- CP230: setting of the slope of the climatic curve from 0.0 to 4.0.

**Important**

Set the type of outside sensor model used via the **AP056** setting



Note

Explain to the user how to select a different temperature curve and how the outdoor sensor regulates the boiler flow temperature.



Important

When an OpenTherm controller is connected adjustment of the boiler, e.g. heating temperature, is made using the OpenTherm controller rather than the boiler controls. The boiler controls are overridden by the OpenTherm control. Please check the functionality with the manufacturer of the OpenTherm controller.

Fig.65 Heating curve graph

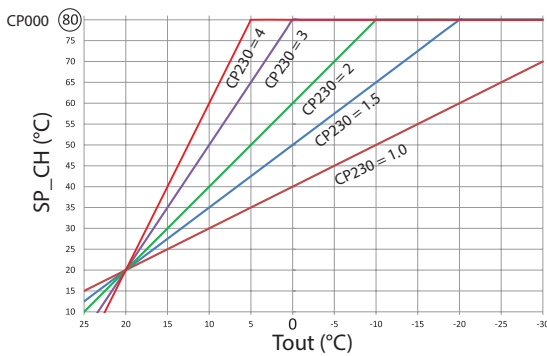
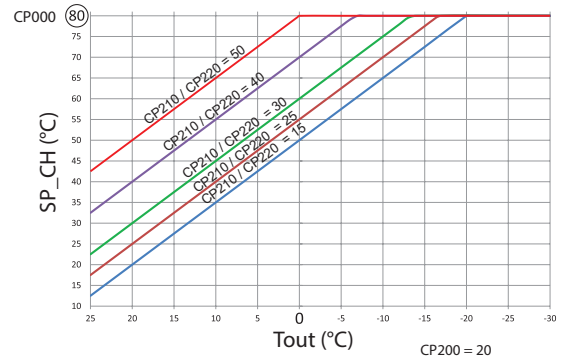
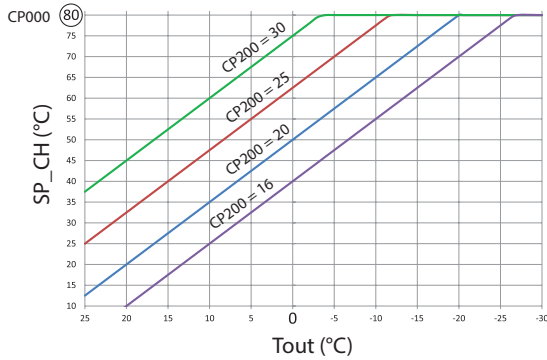

- **Tout**: temperature detected by the outside sensor (° C)
- **SP_CH**: Heating flow temperature setpoint (° C)

BO-0000232

9.4 Reading out measured values

Fig.66 INFO menu access

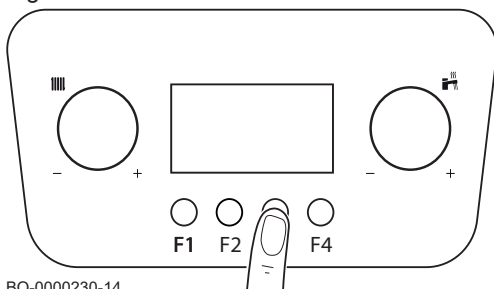

BO-0000230-14

Proceed as described below to access the info menu:

- Press the **F3** key;
- The symbol flashes on the display;
- Press the **F4** key to access the **INFO** menu;
- Turn the knob to view the settings;
- Press the **F1** key to exit.

Tab.28 Read-only parameter list (not editable)

Setting (read only)	Description	Value
AM001	DHW (Domestic Hot Water) mode enabled (0: Disabled, 1: Enabled)	0/1
AM010	Pump speed (0 ÷ 100%)	%
AM011	Service required (0: Disabled, 1: Enabled)	0/1
AM012	Status of appliance	List of statuses
AM014	Sub Status of appliance	List of sub-statuses
AM015	Pump operation (0: Disabled, 1: Enabled)	0/1

Setting (read only)	Description	Value
AM016	Flow temperature	°C
AM018	Return temperature	°C
AM019	Actual water pressure in central heating system	bar
AM024	Current output of the boiler	0/100%
AM027	Outside temperature	°C
AM036	Flue gas temperature	°C
AM037	Status of the 3-way valve (0: Heating, 1: DHW)	0/1
AM040	Outgoing DHW temperature check	°C
AM091	Season mode (0: winter, 3: summer)	0/3
AM101	Internal set point	°C
BM000	DHW temperature	°C
CM030	Current room temperature for zone	°C
CM120	Current operating mode in the zone (0: Disabled, 1: Enabled)	0/1
CM190	Zone ambient set point	°C
CM210	Outside temperature in the zone	°C
CM280	Zone calculated set point	°C
DM001	Temperature of the DHW tank	°C
DM002	Outgoing DHW flow speed	l/min
DM005	Solar system DHW temperature	°C
DM009	Primary operating mode (0: Programming, 1: Manual, 2: Antifreeze/Holiday)	0/1/2
DM019	DHW mode active (1: Comfort, 2: Low, 3: Holiday, 4: Antifreeze)	1/2/3/4
DM029	DHW temperature set point	°C
GM001	Actual fan RPM	rpm
GM002	Actual fan RPM setpoint	rpm
GM003	Flame detected (0: Not detected, 1: Detected)	0/1
GM004	Gas valve (0: Open, 1: Closed, 2: Off)	0/1/2
GM007	Start-up (0: Off, 1: On)	0/1
GM008	Actual flame current measured	µA
GM012	Contact release signal X16 (0: No; 1: Yes)	0/1
GM013	Boiler shutdown signal input (0: Open, 1: Closed)	0/1
GM044	Reason for shutdown checked (0: None) 1. Heating Stoppage 2. DHW Stoppage 3. Awaiting burner ignition 4. Heating flow temperature above maximum value 5. Heating flow temperature above the starting value 6. Heat exchanger temperature above the starting value 7. Average heating flow temperature value above the starting value 8. Heating flow temperature above the setpoint value 9. Temperature difference between flow and return too great 10. Heating flow temperature above the shutdown value 11. Heat request before the minimum wait time between two consecutive requests 12. Shutdown caused by flame value being too low 13. Solar temperature above the shutdown value	0/13

9.4.1 Statuses and sub-statuses

- The **STATUS** is the operating phase of the boiler at the moment of display. To view the status, select the parameter **AM012**. The **SUB-STATUS** is the instantaneous operation the boiler is performing at the moment of display. To view the sub-status, select the parameter **AM014**.

Tab.29 List of statuses

STATUS	
Standby	0
Heat request	1
Burner ignition	2
Operation in heating mode	3
Operation in domestic water mode	4
Burner off	5
Pump post circulation	6
Burner shutdown to reach the temperature setpoint	8
Temporary fault	9
Permanent fault (fault to be reset manually)	10
Chimney sweep function at minimum output	11
Chimney sweep function at maximum output in heating mode	12
Chimney sweep function at maximum output in domestic water mode	13
Manual heat request	15
Frost protection function active	16
Venting function active	17
Boiler reset in progress	19

Tab.30 List of sub-statuses





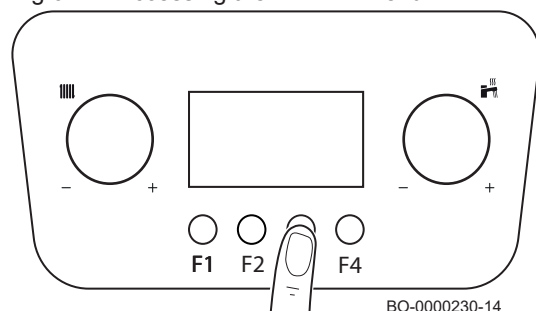

SUB-STATUS	
Standby	0
Wait time until next ignition in heating mode	1
Pre-ventilation	13
Burner ignition signal sent to safety core	15
Burner pre-ignition	17
Burner ignition	18
Flame check	19
Fan operation during ignition attempts	20
Operation at set temperature setpoint	30
Operation at limited temperature setpoint	31
Operation at required output	32
Level 1 gradient detected	33
Level 2 gradient detected	34
Level 3 gradient detected	35
Flame protection active	36
Stabilisation time	37
Boiler start at minimum output	38
Operation in heating mode has been interrupted by a domestic hot water request. Restart from power output in which it was interrupted.	39
Post ventilation	41
Fan off	44
Output reduction due to high flue gas temperature	45
Pump post circulation	60

9.5 Reading meters

Fig.67 Accessing the METER menu



Proceed as described below to access the Meter menu:

- Press the **F3** key;
- The **i** symbol flashes on the display;
- Turn the knob  until the  symbol appears, then press the **F4** key to confirm;
- Turn the  knob until you reach the required meter, then press the **F4** key to confirm;
- To access the meters at the installer level, turn the  knob until you reach the **SVC** symbol then press the **F4** key to confirm;
- Use the  knob to enter code **0012** and confirm by pressing the **F4** key
- Turn the  knob until you reach the required meter, then press the **F4** key to confirm;
- press **F1** to exit.

Tab.31 List of meters (read only)

Meters	Level	Description
AC001	User	Number of boiler power supply hours
AC016	Installer	Filling counter, counts the amount of filling cycles
AC002	Installer	Number of boiler operating hours after last maintenance operation
AC003	Installer	Number of boiler power supply hours after last maintenance operation
AC004	Installer	Failed start-up attempts after last maintenance operation
AC005	User	Indicative energy consumption [kW/h] in heating mode
AC006	User	Indicative energy consumption [kW/h] in domestic hot water (DHW) mode
AC026	Installer	Number of pump operating hours
AC027	Installer	Number of pump start-ups
CLR	Installer	Resetting of all meters (to be confirmed by pressing the F4 key) NOTE: This parameter is only displayed if AP010 ≠ 0
DC001	Installer	Total energy consumption used by domestic hot water (DHW)
DC002	Installer	Number of domestic hot water cycles (three-way valve switching)
DC003	Installer	Number of hours in domestic hot water mode (three-way valve switching)
DC004	Installer	Number of burner start-ups for domestic hot water mode
DC005	Installer	Number of burner start-up hours for domestic hot water mode
GC007	User	Failed start-up attempts
PC001	Installer	Indicative electrical energy consumption [kW/h] in heating mode
PC002	Installer	Number of burner start-ups for heating and domestic hot water mode
PC003	Installer	Number of burner start-up hours for heating and domestic hot water mode
PC004	Installer	Burner flame leaks

10 Maintenance

10.1 General



Warning

When changing components ensure that both the gas and electrical supplies to the boiler are isolated before any work is started. When the component has been changed recommission the boiler. Always examine any seals or gaskets, replacing where necessary. The case front panel **MUST** seal effectively against the boiler side panels.



Warning

After servicing or performing any maintenance on the boiler ensure that

Both flue test point plugs are in place

The front cover is correctly fitted

The front cover securing screws are fully tightened

For reasons of safety and economy, it is recommended that the boiler is serviced annually. Servicing must be performed by a competent person in accordance with BS 7967-4.

After servicing, complete the relevant Service Interval Record section of the Benchmark Commissioning Checklist at the rear of this publication.



Important

During routine servicing, and after any maintenance or change of part of the combustion circuit, the following must be checked:-

The integrity of the complete flue system and the flue seals by checking air inlet sample to eliminate the possibility of recirculation. **O₂ ≥ 20.6% & CO₂ < 0.2%**

The integrity of the boiler combustion circuit and relevant seals.

The operational gas inlet pressure and the gas rate.

The combustion performance as described in "Check the Combustion Performance" below.

Competence to carry out checking combustion performance BS 6798

"Specification for Installation & Maintenance of Gas Fired Boilers not exceeding 70kWh" advises that:-

The person carrying out a combustion measurement should have been assessed as competent in the use of a flue gas analyser and the interpretation of the results.

The flue gas analyser used should be one meeting the requirements of BS 7927 or BS-EN50379-3 and be calibrated in accordance with the analyser manufacturers' requirements.

Competence can be demonstrated by satisfactory completion of the CPA1 ACS assessment, which covers the use of electronic portable combustion gas analysers in accordance with BS 7967, Parts 1 to 4.

Check the Combustion Performance (CO/CO₂ ratio) Set the boiler to operate at maximum rate.



See

Checking combustion - chimney sweep mode, page 49 for details.

Fig.68 Flue adaptor test points

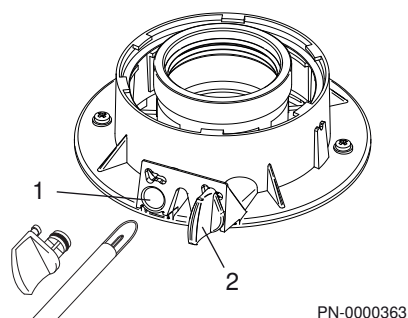

1. Remove the plug from the combustion test point.
2. Insert the analyser probe.
3. Follow the combustion procedure on page 48 (figure 46).

**Warning**

Ensure that both flue test point plugs are in place after checking combustion.

10.2 Maintenance message

Fig.69 Maintenance message

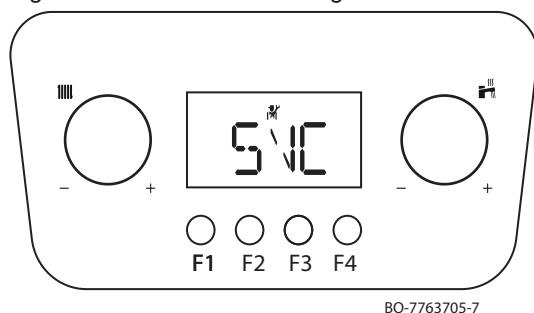

The purpose of this function is to warn the user that the boiler requires maintenance.

When the letters **SVC** appear on the screen and the symbol  flashes, the boiler requires maintenance. Contact your installer.

The boiler is delivered with this function disabled. Proceed as follows to enable notifications on the display:

1. Go to the settings menu;
2. Enable setting **AP010**.
3. Apply the **AP011** setting by entering the number of hours the boiler has been in operation (from the moment the boiler was first supplied with electric power irrespective of the number of times the burner has been switched on and off).
4. Enter the number of burner start-up hours using the **AP009** parameter.

10.2.1 Service notification

When the boiler needs to be serviced, a request message appears on the display. Use the automatic assistance notification for preventative maintenance to reduce interruptions to a minimum.

**Important**

Maintenance must be carried out within two months of notification.

**Important**

If the modulating thermostat is connected to the boiler, this thermostat can also display the message SERVICE. Consult the thermostat manual.

**Important**

Reset SERVICE notification after maintenance is complete.

Fig.70 Resetting displayed message

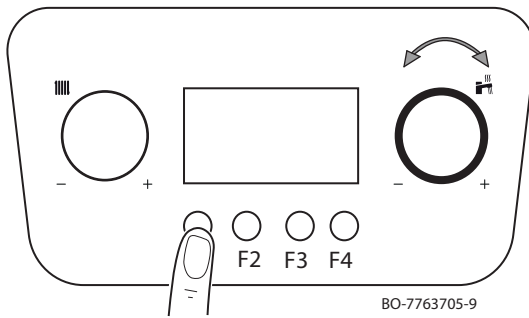

10.2.2 Resetting the displayed maintenance message

Reset the displayed maintenance message once the stated maintenance service has been carried out, as described below:

1. Press the **F1** key.
2. Turn the  knob until the code **0012** is displayed.
3. Press the **F4** key to confirm and reset the maintenance message.



Important

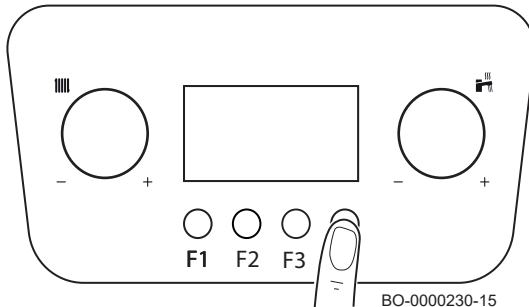

The maintenance message is only active if parameter AP010 ≠ 0.

Fig.71 Resetting upcoming message



10.2.3 Resetting the upcoming maintenance message

Reset an upcoming maintenance message once the intermediate maintenance service has been carried out.

1. Navigate to the Counter menu.
2. Press the **F4** key to open the menu.
3. Turn the  knob until the code **SVC** is displayed.
4. Press the **F4** key to access the maintenance message.
5. Turn the  knob until the code **0012** is displayed.
6. Press the **F4** key to confirm..
7. Turn the  knob until the code **CLR** is displayed.
8. Press the **F4** key for around 3 seconds, to confirm and reset the maintenance message.
⇒ The display shows **DONE**. The maintenance message is reset.
9. Press the **F1** key several times to return to the main screen.

10.3 Standard inspection and maintenance operations

10.3.1 Annual Servicing

**Warning**

Ensure that the boiler is cool. Ensure that both the gas and electrical supplies to the boiler are isolated.

**Caution**

Always examine any seals or gaskets, replacing where necessary. Where a seal or gasket is supplied with a spare part it should be used, irrespective of the condition of the original. Use only original spare parts that are intended for use with this type of boiler.

**Important**

When performing any inspection or maintenance, personal protective equipment must be used where appropriate.

1. Ensure that both the gas and electrical supplies to the boiler are isolated and that the boiler is cool.
2. Remove the case front panel and hinge down the control panel.
3. Carefully examine all seals and gaskets, replacing if necessary. Look for any evidence of leaks or corrosion and if found determine and rectify the cause.
4. Complete the relevant Service Interval Record section of the Benchmark Commissioning Checklist at the rear of this publication and then hand it back to the user.

10.3.2 Checking the water pressure

In order for the boiler to operate correctly, the pressure of the water in the heating circuit, shown on the display, must be between **1.0** and **1.5** bar. If necessary, restore the water pressure as described in the chapter entitled "Filling the installation".

10.3.3 Checking the expansion vessel

Check the expansion vessel and replace it if necessary. Check its pre-charge every year and restore the pressure to 1 bar if necessary.

10.3.4 Checking the flue gas discharge and the air supply

Check the entire line of flue gas pipes, in particular the tightness of the flue gas evacuation and combustion air intake connections.

10.3.5 Checking the combustion

Measure the O₂/CO₂ contents and the temperature of the flue gases at the flue gas measuring point. To do this, proceed as follows:

- Heat the water in the boiler to a temperature of approx. 70°C. Unscrew the plug of the flue gas measurement point (exhaust system adaptor).
- Measure the content of O₂/CO₂ in the flue gas using the measuring equipment. Compare this with the control value.

10.3.6 Checking the automatic air vent

Check that the boiler pump venting valve is working. In the event of a leak, replace the valve.

10.3.7 Cleaning the siphon

The front panel must be removed to extract the siphon (A). Proceed as described below:

- Lower the panel (1);
- Remove the clip (2);
- Unfasten the pipe from the heat exchanger (3);
- Remove the siphon (4) and clean it;
- Replace, if necessary, all the gaskets present;
- Fill the siphon with water and reposition it in its seat (5).

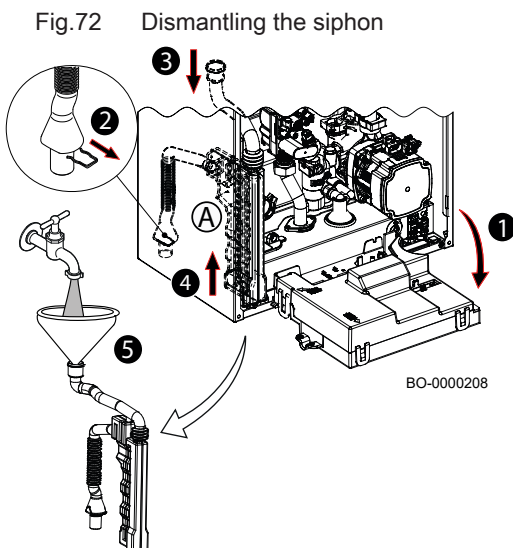
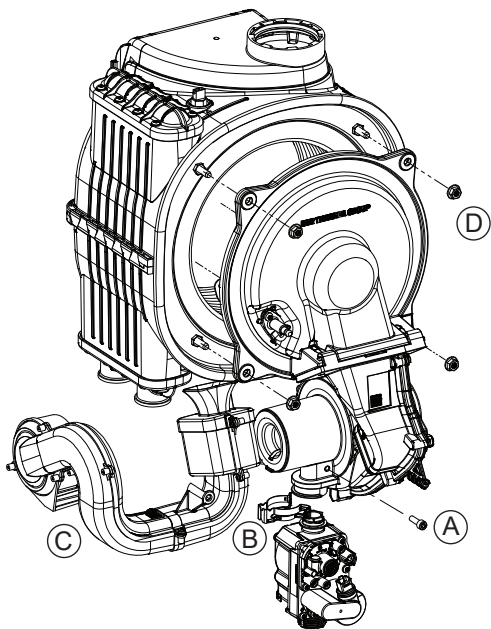

Fig.73 Removing the air-gas system



BO-7696477-01

10.3.8 Checking the burner and cleaning the heat exchanger



Warning

Dust released from the front insulation panel and the rear insulation panel can harm your health.

- Clean the heat exchanger with only a soft brush and water.
- Avoid contact with the rear and front plate
- Do not use steel brushes or compressed air.



Danger

In the case of maintenance/disassembly of the boiler combustion circuit installed on a collective flue in positive pressure, take the necessary precautions to prevent the fumes from other boilers installed on the collective flue from entering the room where the boiler is installed.

Proceed as described below for cleaning:

1. Isolate the unit from the power supply (disconnect the boiler from the main power supply).
2. Cut off the gas supply to the boiler.
3. Close the hydraulic cocks.
4. Remove the front panel.
5. Remove the entire air-gas unit, unscrew the screw (A) and the clip (B) located between the fan and the gas valve.
6. Remove the silencer (C).
7. Unscrew the 4 M6 locknuts (D) on the burner door.
8. Check the condition of the detection/ignition electrode. Replace the electrode if necessary.
9. Check the condition of the burner, the gasket and the insulation panel.
10. The burner does not require any maintenance, it is self-cleaning.
11. Check that there are no cracks and/or other damage on the surface of the dismantled burner. If the burner is damaged, replace it.
12. Replace the burner flange gasket.
13. Check the front insulation panel for cracks, damage, moisture, ageing and deformation. Replace the insulation panel if in doubt.
14. To clean the upper part of the heat exchanger (combustion chamber), use a vacuum cleaner and a brush with plastic bristles.
15. Thoroughly clean with the vacuum cleaner again without the end piece (brush).
16. Make sure (using a mirror, for example) that there is no visible dust residue. Vacuum up any residue.
17. It is forbidden to clean the combustion chamber with any unauthorised chemical products and, in particular, ammonia, hydrochloric acid, sodium hydroxide (caustic soda) etc.
18. Generously wet the surfaces to be cleaned using a manual sprayer containing a solution of water and vinegar. Do not use it on excessively hot surfaces (max. 40 °C). Wait approx. 7-8 minutes then brush the surface without rinsing it. Repeat the process. Wait another 8 minutes and then brush again. If the result is not satisfactory, repeat the operation.
19. Rinse with water. The water will flow out of the heat exchanger through the condensate drain siphon. Wait another 20 minutes and use a powerful water jet to wash away the dirt particles. Do not aim the water jet directly at the insulating surface on the rear of the heat exchanger.
20. To re-assemble, perform the above actions in reverse order.



Caution

The maximum tightening torque of the four M6 nuts (D) fastening the flange is 5 Nm (+/- 0.5).

Fig.74 Electrode distance

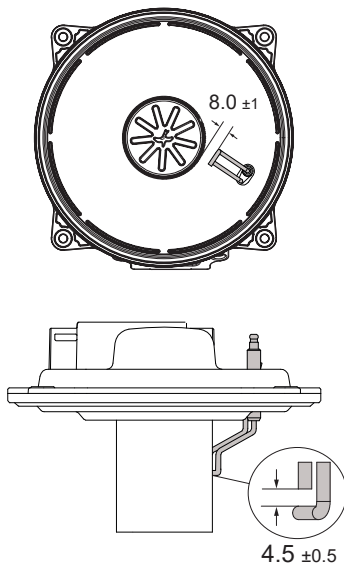

BO-7696477-2

10.3.9 Electrode distances

Verify the distances between the electrode and the burner and between

10.3.10 Water unit



Caution

Do not use tools to remove components from inside the water unit (e.g. filter).

For certain user areas, where domestic water hardness values exceed 20 °F (200 mg of calcium carbonate per litre of water) it is recommended to install a polyphosphate batcher or equivalent system complying with the prevailing standards.

CLEANING THE DOMESTIC WATER FILTER

The domestic water filter is housed inside a suitable removable cartridge positioned on the cold water inlet (B). Proceed as follows to clean:

1. Disconnect the power supply to the boiler;
2. Close the domestic water inlet cock;
3. Empty the water from the domestic water circuit by opening a user cock;
4. Remove the clip (1-B) as shown in the figure and remove the cartridge (2-B) containing the filter, taking care not to apply excessive force;
5. Remove any impurities and deposits from the filter;
6. Fit the filter back inside the cartridge and reinsert it into its seat, securing it with its clip;



Notice

If the O-rings in the water unit need to be replaced and/or cleaned, do not use oil or grease as a lubricant, but only Molykote 111.

Fig.75 Water unit parts

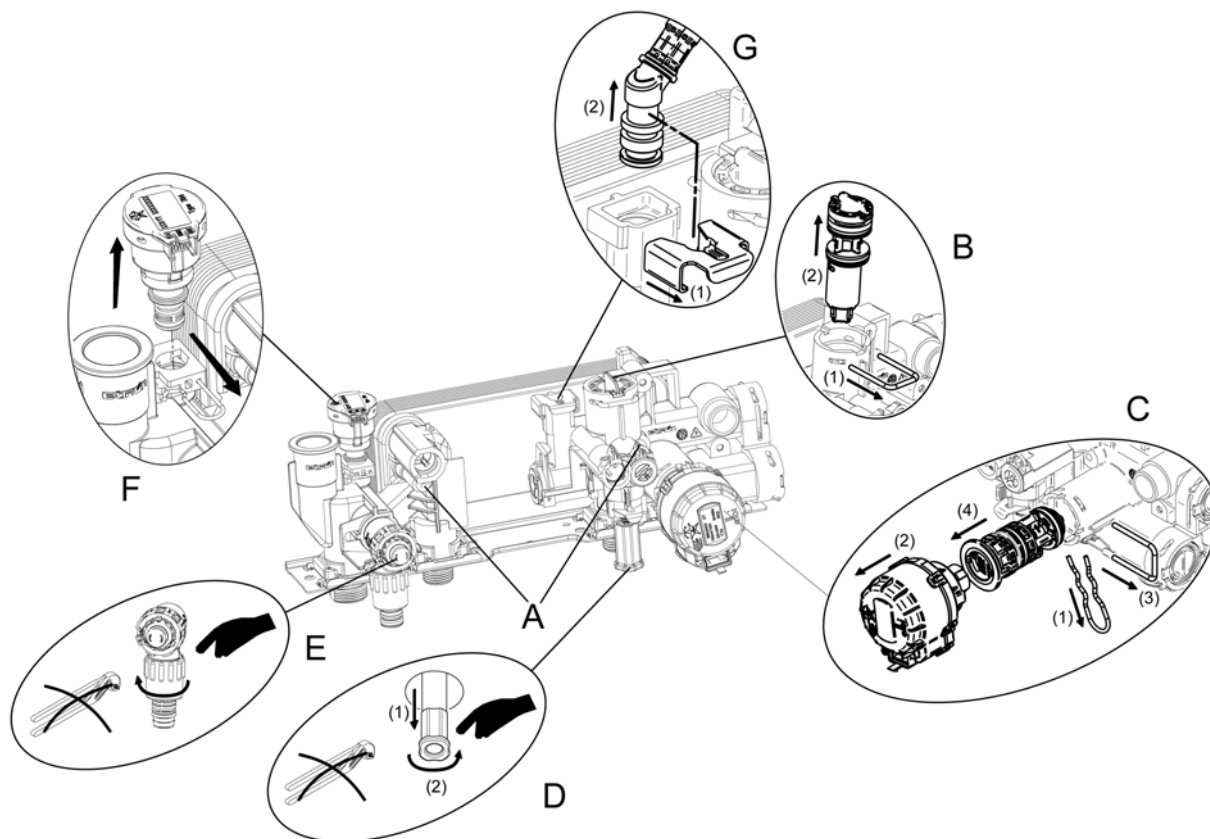

10.3.11 Removing limescale

The domestic water circuit can be cleaned after removing the water-water heat exchanger from its seat, by unscrewing the two front screws (A).

For the cleaning operations, you must:

- Disconnect the power supply to the boiler.
- Cut off the gas supply to the boiler.
- Close the heating system return and flow cocks.
- Empty the water contained in the heating circuit by opening the cock (E).
- Close the domestic water inlet cock.
- Empty the water from the domestic water circuit by opening a user cock.
- Remove the exchanger by unscrewing the two screws (A).
- Clean the plate heat exchanger with a descaling product (e.g. formic or citric acid with a pH value of around 3). After cleaning, rinse thoroughly under running water.

To re-assemble, perform the above actions in reverse order.



Caution

The maximum tightening torque for the two fastening screws (A) for the plate heat exchanger is 4 Nm.



For more information, see
Water treatment, page 19

10.4 Specific maintenance operations

Fig.76 Remove detection/spark ignition electrode

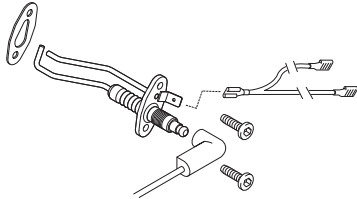

PN-0000331

10.4.1 Detection/ignition electrode replacement

Replace the detection//ignition electrode in the following cases:

1. Ionisation current $< 4 \mu\text{A}$. To do this, activate the "chimney sweep function" (chapter "Combustion settings") and set the boiler to the minimum power. The ionisation value is visible with setting GM008 (chapter "Reading out measured values").
2. Electrode worn.
3. Distances out of range (chapter "Electrode distance").

To remove the electrode:

- Disconnect the power supply to the boiler.
- Cut off the gas supply to the boiler.
- Remove the front panel on the boiler (case) and remove the electrode pin and the earthing cable.
- Unscrew the 2 screws on the ignition electrode and remove it.
- Fit the new electrode with the gasket. To re-assemble, perform the above actions in reverse order.

10.4.2 Dismantling the water-water exchanger

The stainless steel plate water-water heat exchanger can be easily removed, as described below:

1. Disconnect the power supply to the boiler;
2. Close the gas cock;
3. Close the heating system return and flow cocks.
4. Drain the system, if possible only the boiler, using the specific drain cock (E);
5. Empty the water contained in the domestic water circuit by opening a user cock;
6. Remove the silencer, then loosen the two Allen screws $\varnothing 6 \text{ mm}$ (A) securing the heat exchanger and remove it from its seat;
7. Use a natural product (e.g. vinegar) to clean the water-water heat exchanger;
8. To re-assemble, perform the above actions in reverse order.

10.4.3 Replacing the 3-way valve

To replace the diverter valve, proceed as follows:

1. Disconnect the power supply to the boiler;
2. Close the gas cock;
3. Cut off the gas supply to the boiler.
4. Close the heating system return and flow cocks.
5. Drain the system, if possible only the boiler, using the specific drain cock.
6. Empty the water from the domestic water circuit by opening a user cock.
7. Disconnect any piping connections.
8. Remove the clip (1).
9. Remove the pressure sensor (2).
10. Remove the fixing spring (3).
11. Remove the safety valve (4).
12. Remove the motor fixing spring (5).
13. Remove the motor (6).
14. To re-assemble, perform the above actions in reverse order.

Fig.77 Remove pump

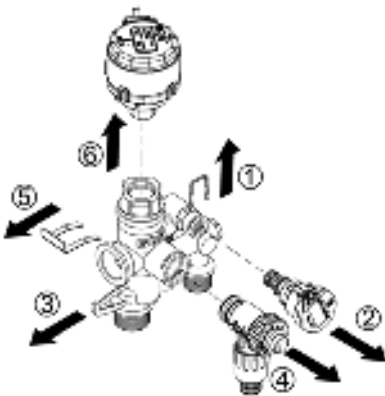
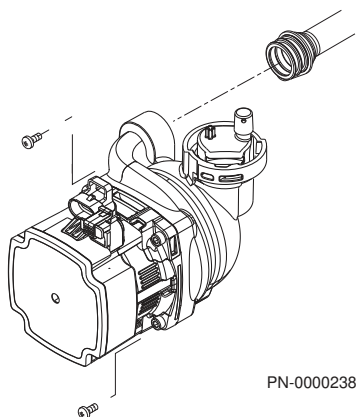

Fig.78 Removing the pump



10.4.4 Pump - replacement



Warning

Take precautions to protect other components from water damage when removing the pump and auto air vent.

1. Hinge the control box down.
2. Close the flow and return isolation taps and drain the boiler primary circuit. Disconnect the electrical plugs from the pump motor.
3. Undo the screws securing the body to the pipe and manifold and draw the pump forward to remove.
4. Examine the 'O' ring seals on the return pipe and manifold, replacing if necessary.
5. Reassemble in reverse order.

10.4.5 Replacing the expansion vessel

Before replacing the expansion vessel, proceed as detailed below:

1. Disconnect the power supply to the boiler.
2. Close the gas cock.
3. Close the main domestic water tap.
4. Close the heating system return and flow cocks.
5. Open the boiler drain cock.

The expansion vessel is inside the boiler on the side, to the right.

Fig.79 Accessing the parameters

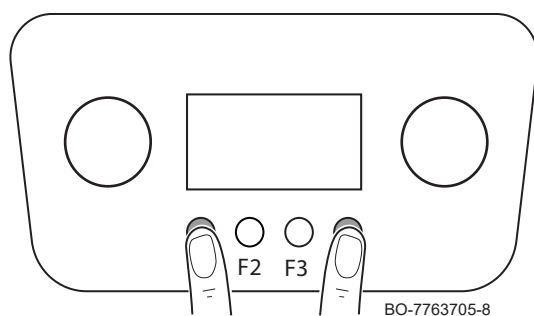

10.4.6 Replacing the PCB

After replacing the main board, power up the boiler electrically. Parameters **CN1** and **CN2** will automatically appear on the display.

Modify the parameters with the data shown on the serial number plate:

- Turn knob  to modify the parameters;
- Press the **F4** key to store the set value.

Parameters **CN1** and **CN2** can also be accessed from the main menu to carry out the replacement. Press the two external buttons on the control panel simultaneously for about 40 seconds.



Caution

Please note that resetting the **CN1** and **CN2** settings with data on the data plate deletes any previous setting. If changing the gas, for example, remember to set the correct calibration for the gas valve.

11 Troubleshooting

11.1 Temporary and permanent faults

The codes on the display indicate two types of fault: volatile and permanent. The first item shown on the display is a letter followed by a two-digit number. The letter indicates the type of fault: temporary (**H**) or permanent (**E**). The number indicates the group in which the fault that has occurred is classified according to its impact on safe and reliable operation. The second item shown flashes alternately with the first and consists of a two-digit number that indicates the type of fault which has occurred (see the following fault tables).

TEMPORARY FAULT (A/H.x.x.)

A temporary fault is shown on the display by the letter "A" or "H" followed by a number (group). A temporary fault is a type of fault that does not cause a permanent stoppage of the boiler. It has the following characteristics:

A: The appliance continues to operate. It disappears as soon as the cause has been resolved.

H: Disappears when the error condition is removed, in some cases even after 10 minutes.

PERMANENT FAULT (E.x.x)

A permanent fault is shown on the display by the letter "E" followed by a number (group). Press the RESET button for one second. If faults are shown frequently, contact our authorised technical assistance centre.

E: Stoppage, reset required..

11.2 Error codes

Tab.32 List of temporary faults

DISPLAY		DESCRIPTION OF TEMPORARY FAULTS	CAUSE – Check/Solution <i>An installer is required for most checks and solutions.</i>
Group code	Specific code		
H.00	.42	Pressure sensor open/faulty	SENSOR/CONNECTION PROBLEM Check the operation of the pressure sensor Check the sensor/PCB connection
H.01	.00	Temporary communication failure in the PCB	The error is resolved automatically
H.01	.05	Maximum temperature difference value between flow and return reached.	INSUFFICIENT CIRCULATION Check the boiler/installation circulation Activate a manual venting cycle Check the installation pressure OTHER CAUSES Check the cleanliness of the exchanger Check the operation of the temperature sensors Check the temperature sensor connection
H.01	.08	Flow temperature increase in heating mode too quick.	INSUFFICIENT CIRCULATION Check the boiler/installation circulation Activate a manual venting cycle Check the installation pressure Check the operation of the pump OTHER CAUSES Check the cleanliness of the exchanger Check the operation of the temperature sensors Check the temperature sensor connection
H.01	.14	Maximum flow or return temperature value reached.	INSUFFICIENT CIRCULATION Check the boiler/installation circulation Activate a manual venting cycle

DISPLAY		DESCRIPTION OF TEMPORARY FAULTS	CAUSE – Check/Solution <i>An installer is required for most checks and solutions.</i>
Group code	Specific code		
H.01	.18	No water circulation (temporary).	INSUFFICIENT CIRCULATION Check the installation pressure Activate a manual venting cycle Check the operation of the pump Check the boiler/installation circulation TEMPERATURE SENSOR ERROR Check the operation of the temperature sensors Check the temperature sensor connection
H.01	.21	Flow temperature increase during domestic hot water operation too fast.	INSUFFICIENT CIRCULATION Check the installation pressure Activate a manual venting cycle Check the operation of the pump Check the boiler/installation circulation TEMPERATURE SENSOR ERROR Check the operation of the temperature sensors Check the connection of the temperature sensors
H.02	.00	Reset in progress.	It resolves itself
H.02	.02	Waiting for configuration settings to be entered (CN1,CN2).	CN1/CN2 CONFIGURATION MISSING Configure CN1/CN2
H.02	.03	Configuration settings (CN1,CN2) not entered correctly.	Check configuration CN1/CN2 Configure CN1/CN2 correctly
H.02	.04	PCB settings cannot be read.	MAIN PCB ERROR Configure CN1/CN2 Replace the main PCB
H.02	.05	Setting memory not compatible with the boiler PCB type.	Contact the Service Network
H.02	.07	Low pressure in heating circuit (water filling required).	Check the installation pressure and restore Check the expansion vessel pressure Check for boiler/installation leaks
H.02	.09	Partial stoppage of the boiler (antifreeze function active)	SIGNAL INDICATING BLOCKING INPUT Contact X15 open, check connected devices Parameter configuration error: Check AP001
H.02	.10	Total stoppage of the boiler (antifreeze function not active)	SIGNAL INDICATING BLOCKING INPUT Contact X15 open, check connected devices Parameter configuration error: Check AP001
H.02	.70	External unit heat recovery test failed	PCB accessory error SCB-09 Check the device connected to contact X9
H.03	.00	No identification data for boiler safety device.	MAIN PCB ERROR Contact the Service Network
H.03	.02	Temporary flame loss	ELECTRODE PROBLEM Check the electrode connection and wiring Check the condition of the electrode GAS SUPPLY Check the gas supply pressure Check the gas valve calibration FLUE GAS PIPES Check the pipes and the terminal
H.03	.05	Power supply voltage too low	Check the mains voltage
H.03	.54	Temporary flame loss Shutdown due to the power supply voltage being too low	ELECTRODE PROBLEM Check the electrode electrical connections Check the condition of the electrode GAS SUPPLY Check the gas inlet pressure Check the gas valve calibration FLUE GAS EXHAUST PIPE Check the air intake and flue gas exhaust terminal Check the power supply voltage

Tab.33 List of permanent faults (boiler stoppage, reset required)

DISPLAY		DESCRIPTION OF PERMANENT FAULTS (RESET)	CAUSE – Check/Solution <i>An installer is required for most checks and solutions.</i>
Group code	Specific code		
E.00	.04	Return temperature sensor disconnected	SENSOR/CONNECTION PROBLEM Check the operation of the temperature sensor Check the sensor/PCB connection
E.00	.05	Return temperature sensor short circuited	SENSOR/CONNECTION PROBLEM Check the operation of the sensor Check the sensor/PCB connection
E.00	.16	DHW tank temperature sensor not connected	SENSOR OPEN Check the operation of the sensor Check the sensor/PCB connection When removing a domestic hot water tank, set parameter DP150=1
E.00	.17	DHW tank temperature sensor short-circuited	SENSOR CLOSED Check the operation of the sensor Check the sensor/PCB connection
E.00	.20	The flue gas temperature sensor is not connected or measured a temperature below the range	SENSOR OPEN Check the operation of the sensor Check the sensor/PCB connection
E.00	.21	The flue gas temperature sensor has short-circuited or measured a temperature above the range	SENSOR CLOSED Check the operation of the sensor Check the sensor/PCB connection
E.01	.04	Flame loss detected five times in 24 hours	GAS SUPPLY Check the gas supply pressure Check the gas valve calibration ELECTRODE PROBLEM Check the electrode connection and wiring Check the condition of the electrode FLUE GAS PIPES Check the air intake and flue gas exhaust pipes EXCHANGER ON FLUE GAS SIDE BLOCKED Check the cleanliness of the exchanger MAINS VOLTAGE Check the power supply voltage
E.01	.12	Temperature measured by return sensor greater than flow temperature	SENSOR/CONNECTION PROBLEM Check that the sensors are positioned the correct way around Check that the flow sensor is in the correct position Check the return temperature in the boiler Check the operation of the sensors
E.01	.17	No water circulation (permanent)	INSUFFICIENT CIRCULATION Check the installation pressure Activate a manual venting cycle Check the operation of the pump Check the boiler/installation circulation SENSOR ERROR Check the operation of the temperature sensors Check the temperature sensor connection
E.01	.20	Maximum flue gas temperature reached	EXCHANGER ON FLUE GAS SIDE BLOCKED Check the cleanliness of the exchanger
E.02	.13	Total stoppage of the boiler (antifreeze function not active)	SIGNAL INDICATING BLOCKING INPUT Contact X15 open, check connected devices Parameter configuration error: Check setting AP001
E.02	.17	Permanent communication failure in the PCB	MAIN PCB ERROR Check for any electromagnetic interference Contact the Service Network

DISPLAY		DESCRIPTION OF PERMANENT FAULTS (RESET)	CAUSE – Check/Solution <i>An installer is required for most checks and solutions.</i>
Group code	Specific code		
E.02	.35	Critical safety device disconnected	COMMUNICATION FAULT Start the auto-detect function (parameter AD) Check the devices connected to contact X9
E.02	.39	Minimum pressure not reached after 6 minutes of automatic filling	AUTOMATIC FILLING ERROR Check automatic filling is working
E.02	.47	Connection to external device unsuccessful	ELECTRICAL CONNECTION ERROR Start the auto-detect function (parameter AD)) Check the electrical connections of external devices.
E.04	.01	Flow temperature sensor short circuited	SENSOR/CONNECTION PROBLEM Check the sensor/PCB connection Check the operation of the sensor
E.04	.02	Flow temperature sensor disconnected	SENSOR/CONNECTION PROBLEM Check the sensor/PCB connection Check the operation of the sensor
E.04	.03	Maximum flow temperature exceeded or flow temperature sensor short circuited	INSUFFICIENT CIRCULATION Check the boiler/installation circulation Activate a manual venting cycle Check the operation of the sensors
E.04	.08	Maximum safe temperature value reached	INSUFFICIENT CIRCULATION Check the pressure in the installation Switch on the manual degassing function Check that the pump is working Check the circulation in the boiler/installation OTHER POSSIBLE CAUSES Check the safety thermostat connection Check that the safety thermostat is working correctly
E.04	.10	Burner failed to ignite after 4 attempts	GAS SUPPLY Check the gas supply pressure Check the gas valve electrical connection Check the gas valve calibration Check the operation of the gas valve ELECTRODE PROBLEM Check the electrode electrical connections Check the electrode condition OTHER CAUSES Check the operation of the fan Check the condition of the flue gas exhaust (blockages)
E.04	.12	Ignition failure for monitoring parasitic flame	Check the ground circuit Check the power supply voltage Check the electrode conditions
E.04	.13	Fan blade blocked or maximum rpm exceeded	FAN/PCB PROBLEM Check the PCB-fan connection Check the fan operation
E.04	.17	Fault in gas valve control circuit	MAIN PCB ERROR Check the electrical connections for the gas valve
E.04	.18	The flow temperature is below the minimum temperature or the flow temperature sensor is not connected	SENSOR/CONNECTION PROBLEM Check the sensor/PCB connection Check the operation of the sensor
E.04	.23	Communication internal stoppage	Switch the power supply off and on again and then RESET
E.04	.29	Communication internal stoppage	Switch the power supply off and on again and then RESET
E.04	.254	Fault in gas valve control circuit	MAIN PCB ERROR Check the electrical connections

Tab.34 List of warnings

DISPLAY		DESCRIPTION OF WARNINGS BEFORE A FAULT IS DETECTED	CAUSE – Check/Solution
Group code	Specific code		
A.00	.28	Solar temperature sensor is either removed or measures a temperature below range	Check the solar temperature sensor wiring. Replace the sensor if necessary. In case of removal of the solar tank, set the parameter DP150=1.
A.00	.29	Solar temperature sensor is either shorted or measures a temperature above range	Check the solar temperature sensor wiring. Replace the sensor if necessary.
A.00	.34	Outdoor temperature sensor expected but not detected	OUTDOOR SENSOR NOT DETECTED Enter the correct value of the parameter AP091 Connect the outdoor sensor Outdoor sensor is not connected correctly
A.02	.06	Low pressure in heating circuit	Check the installation pressure and restore Check the expansion vessel pressure Check for boiler/installation leaks
A.02	.36	Functional device disconnected	COMMUNICATION FAULT Start the auto-detect function (parameter AD) Check the devices connected to contact X9
A.02	.37	Passive functional device disconnected	COMMUNICATION FAULT Start the auto-detect function (parameter AD) Check the devices connected to contact X9
A.02	.45	Connection error	COMMUNICATION FAULT Start the auto-detect function (parameter AD))
A.02	.46	Device priority error	COMMUNICATION FAULT Start the auto-detect function (parameter AD))
A.02	.48	Unit function configuration error	ELECTRICAL CONNECTION ERROR Start the auto-detect function (parameter AD)) Check electrical connections of external devices
A.02	.49	Failed node initialisation	ELECTRICAL CONNECTION ERROR Start the auto-detect function (parameter AD)) Check electrical connections of external devices
A.02	.54	Open Therm bus power supply error	Check the devices connected to contact X17 - Terminal board M2 (7-8)
A.02	.55	Incorrect or missing serial number	Contact the Service Network
A.02	.76	Internal memory reserved for full customisation of settings. No further changes can be made	Contact the Service Network

**Important**

When connecting a Room Unit/Control Unit to the boiler, the code “254” is always shown in the event of a fault. Read the fault code shown on the boiler display.

12 Decommissioning

12.1 Disassembly

**Warning**

Only qualified professionals are authorised to work on the boiler and the heating system.

Proceed as follows to disassemble the boiler:

1. Switch off the boiler.
2. Disconnect the power supply to the boiler.
3. Close the gas valve to the boiler.
4. Close the inlet cock for domestic cold water in the boiler.
5. Tap domestic water by opening a cock to relieve pressure from the domestic water circuit.
6. Drain the heating installation.

**Warning**

If the boiler was in operation, wait for the water contained in the heating installation to cool down.

7. Remove the pipe connecting the boiler to the chimney and close the connection with a plug.
8. Unscrew the hydraulic and gas connections in the lower part of the boiler.

**Warning**

Moving the boiler is a job for two people.

12.2 Recommissioning

**Warning**

Only qualified professionals are authorised to work on the boiler and the heating system.

Should you need to recommission the boiler, follow the instructions for disassembly in the reverse order.

13 Disposal

13.1 Disposal and recycling

The appliance is composed of multiple components made from various different materials, such as steel, copper, plastic, fibreglass, aluminium, rubber, etc..

These materials may be highly pollutant. This means that the boiler must be disposed of correctly by contacting staff at the nominated disposal facility or by taking it to a centre that is authorised to dispose of bulky waste (domestic appliances).

Fig.80 Recycling



Fig.81 Cutting the power supply

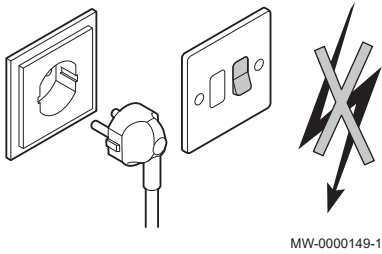

Warning

Removal and disposal of the boiler must be carried out by a qualified installer in accordance with local and national regulations.

Benchmark Commissioning & Warranty Validation Service Record

It is a requirement that the boiler is installed and commissioned to the manufacturers' instructions and the data fields on the commissioning checklist completed in full.

To instigate the boiler warranty the boiler needs to be registered with the manufacturer within one month of the installation. The warranty rests with the end-user (consumer), and they should be made aware it is ultimately their responsibility to register with the manufacturer, within the allotted time period.

It is essential that the boiler is serviced in line with the manufacturers' recommendations, at least annually. This must be carried out by a competent Gas Safe registered engineer. The service details should be recorded on the Benchmark Service and Interim Boiler Work Record and left with the householder. Failure to comply with the manufacturers' servicing instructions and requirements will invalidate the warranty.



www.hhic.co.uk

This Commissioning Checklist is to be completed in full by the competent person who commissioned the boiler as a means of demonstrating compliance with the appropriate Building Regulations and then handed to the customer to keep for future reference.

Failure to install and commission according to the manufacturers' instructions and complete this Benchmark Commissioning Checklist will invalidate the warranty. This does not affect the customer's statutory rights.

* All installations in England and Wales must be notified to Local Authority Building Control (LABC) either directly or through a Competent Persons Scheme. A Building Regulations Compliance Certificate will then be issued to the customer.

© Heating and Hotwater Industry Council (HHIC)



www.centralheating.co.uk

GAS BOILER SYSTEM COMMISSIONING CHECKLIST & WARRANTY VALIDATION RECORD

Address:															
Boiler make and model:															
Boiler serial number:															
Commissioned by (PRINT NAME):						Gas Safe registration number:									
Company name:						Telephone number:									
Company email:						Company address:									
										Commissioning date:					
Heating and hot water system complies with the appropriate Building Regulations?											Yes				
Optional: Building Regulations Notification Number (if applicable):															
Time, temperature control and boiler interlock provided for central heating and hot water											Yes				
Boiler Plus requirements (tick the appropriate box(s))															
Boiler Plus option chosen for combination boiler in ENGLAND						Weather compensation			Smart thermostat with automation and optimisation						
						Load compensation			Flue Gas Heat Recovery						
Time and temperature control to hot water			Cylinder thermostat and programmer/timer						Combination boiler						
Zone valves			pre-existing			Fitted			Not required						
Thermostatic radiator valves			pre-existing			Fitted			Not required						
Automatic bypass to system			pre-existing			Fitted			Not required						
Underfloor heating			pre-existing			Fitted			Not required						
Water quality															
The system has been flushed, cleaned and a suitable inhibitor applied upon final fill, in accordance with BS7593 and boiler manufacturers' instructions											Yes				
What system cleaner was used?						Brand:			Product:						
What inhibitor was used?						Brand:			Product:						
Primary water system filter			pre-existing			Fitted			Not required						
CENTRAL HEATING MODE measure and record (as appropriate)															
Gas rate (for combination boilers complete DHW mode gas rate)						m ³ /hr			or			ft ³ /hr			
Central heating output left at factory settings?						Yes			No						
If no, what is the maximum central heating output selected?												kW			
Dynamic gas inlet pressure												mbar			
Central heating flow temperature												°C			
Central heating return temperature												°C			
System correctly balanced/rebalanced?						Yes									
COMBINATION BOILERS ONLY															
Is the installation in a hard water area (above 200ppm)?						Yes			No						
Water scale reducer/softener			pre-existing			Fitted			Not required						
What type of scale reducer/softener has been fitted?						Brand:			Product:						
Water meter fitted?						Yes			No						
If yes- DHW expansion vessel			pre-existing			Fitted			Not required						
Pressure reducing valve			pre-existing			Fitted			Not required						
DOMESTIC HOT WATER MODE Measure and record															
Gas rate						m ³ /hr			or			ft ³ /hr			
Dynamic gas inlet pressure at maximum rate												mbar			
Cold water inlet temperature												°C			
Hot water has been checked at all outlets						Yes			Temperature			°C			
CONDENSATE DISPOSAL															
The condensate drain has been installed in accordance with the manufacturers' instructions and/or BS5546/BS6798											Yes				
Point of termination						Internal			External (only where internal termination impractical)						
Method of disposal						Gravity			Pumped						
ALL INSTALLATIONS															
Record the following		At max rate:		CO		ppm		CO ₂		%		CO/CO ₂		Ratio	
		At min rate (where possible)		CO		ppm		CO ₂		%		CO/CO ₂		Ratio	
Where possible, has a flue integrity check been undertaken in accordance with manufacturers' instructions, and readings are correct?											Yes				
The operation of the boiler and system controls have been demonstrated to and understood by the customer											Yes				
The manufacturers' literature, including Benchmark Checklist and Service Record, has been explained and left with the customer											Yes				
Commissioning Engineer's signature															
Customer's signature (To confirm satisfactory demonstration and receipt of manufacturers' literature)															

* All installations in England and Wales must be notified to Local Authority Building Control (LABC) either directly or through a Competent Persons Scheme. A Building Regulations Compliance Certificate will then be issued to the customer.



SERVICE & INTERIM BOILER WORK RECORD

It is recommended that your boiler and heating system are regularly serviced and maintained, in line with manufacturers' instructions, and that the appropriate service / interim work record is completed.

Service provider

When completing a service record (as below), please ensure you have carried out the service as described in the manufacturers' instructions. Always use the manufacturers' specified spare parts.

SERVICE/INTERIM WORK ON BOILER <small>delete as appropriate</small>					Date:	
Engineer name:		Company name:				
Telephone N°:		Gas Safe registration N°:				
Max rate	CO	ppm	CO ₂	%	CO/CO ₂	
Min rate	CO	ppm	CO ₂	%	CO/CO ₂	
Where possible, has a flue integrity check been undertaken in accordance with manufacturers' instructions, and readings are correct?*					yes	
Gas rate:	m ³ /h	OR	ft ³ /h			
Were parts fitted? <small>delete as appropriate</small>	Yes	No				
Parts fitted:						
System inhibitor concentration has been checked and appropriate action taken, in accordance with BS 7593 and boiler manufacturers' instructions. *					yes	n/a
Comments:						
Signature:						

*A System inhibitor efficacy test is required on every annual service in accordance with the manufacturers' instructions and BS 7593. It is only acceptable to not have undertaken this if the service engineers attendance visit was in between annual services to attend a non-water facing component.

SERVICE/INTERIM WORK ON BOILER <small>delete as appropriate</small>					Date:	
Engineer name:		Company name:				
Telephone N°:		Gas Safe registration N°:				
Max rate	CO	ppm	CO ₂	%	CO/CO ₂	
Min rate	CO	ppm	CO ₂	%	CO/CO ₂	
Where possible, has a flue integrity check been undertaken in accordance with manufacturers' instructions, and readings are correct?*					yes	
Gas rate:	m ³ /h	OR	ft ³ /h			
Were parts fitted? <small>delete as appropriate</small>	Yes	No				
Parts fitted:						
System inhibitor concentration has been checked and appropriate action taken, in accordance with BS 7593 and boiler manufacturers' instructions. *					yes	n/a
Comments:						
Signature:						

*A System inhibitor efficacy test is required on every annual service in accordance with the manufacturers' instructions and BS 7593. It is only acceptable to not have undertaken this if the service engineers attendance visit was in between annual services to attend a non-water facing component.

SERVICE/INTERIM WORK ON BOILER <small>delete as appropriate</small>					Date:	
Engineer name:		Company name:				
Telephone N°:		Gas Safe registration N°:				
Max rate	CO	ppm	CO ₂	%	CO/CO ₂	
Min rate	CO	ppm	CO ₂	%	CO/CO ₂	
Where possible, has a flue integrity check been undertaken in accordance with manufacturers' instructions, and readings are correct?*					yes	
Gas rate:	m ³ /h	OR	ft ³ /h			
Were parts fitted? <small>delete as appropriate</small>	Yes	No				
Parts fitted:						
System inhibitor concentration has been checked and appropriate action taken, in accordance with BS 7593 and boiler manufacturers' instructions. *					yes	n/a
Comments:						
Signature:						

*A System inhibitor efficacy test is required on every annual service in accordance with the manufacturers' instructions and BS 7593. It is only acceptable to not have undertaken this if the service engineers attendance visit was in between annual services to attend a non-water facing component.

SERVICE/INTERIM WORK ON BOILER <small>delete as appropriate</small>					Date:	
Engineer name:		Company name:				
Telephone N°:		Gas Safe registration N°:				
Max rate	CO	ppm	CO ₂	%	CO/CO ₂	
Min rate	CO	ppm	CO ₂	%	CO/CO ₂	
Where possible, has a flue integrity check been undertaken in accordance with manufacturers' instructions, and readings are correct?*					yes	
Gas rate:	m ³ /h	OR	ft ³ /h			
Were parts fitted? <small>delete as appropriate</small>	Yes	No				
Parts fitted:						
System inhibitor concentration has been checked and appropriate action taken, in accordance with BS 7593 and boiler manufacturers' instructions. *					yes	n/a
Comments:						
Signature:						

*A System inhibitor efficacy test is required on every annual service in accordance with the manufacturers' instructions and BS 7593. It is only acceptable to not have undertaken this if the service engineers attendance visit was in between annual services to attend a non-water facing component.

SERVICE/INTERIM WORK ON BOILER <small>delete as appropriate</small>					Date:	
Engineer name:		Company name:				
Telephone N°:		Gas Safe registration N°:				
Max rate	CO	ppm	CO ₂	%	CO/CO ₂	
Min rate	CO	ppm	CO ₂	%	CO/CO ₂	
Where possible, has a flue integrity check been undertaken in accordance with manufacturers' instructions, and readings are correct?*					yes	
Gas rate:	m ³ /h	OR	ft ³ /h			
Were parts fitted? <small>delete as appropriate</small>	Yes	No				
Parts fitted:						
System inhibitor concentration has been checked and appropriate action taken, in accordance with BS 7593 and boiler manufacturers' instructions. *					yes	n/a
Comments:						
Signature:						

*A System inhibitor efficacy test is required on every annual service in accordance with the manufacturers' instructions and BS 7593. It is only acceptable to not have undertaken this if the service engineers attendance visit was in between annual services to attend a non-water facing component.

SERVICE/INTERIM WORK ON BOILER <small>delete as appropriate</small>					Date:	
Engineer name:		Company name:				
Telephone N°:		Gas Safe registration N°:				
Max rate	CO	ppm	CO ₂	%	CO/CO ₂	
Min rate	CO	ppm	CO ₂	%	CO/CO ₂	
Where possible, has a flue integrity check been undertaken in accordance with manufacturers' instructions, and readings are correct?*					yes	
Gas rate:	m ³ /h	OR	ft ³ /h			
Were parts fitted? <small>delete as appropriate</small>	Yes	No				
Parts fitted:						
System inhibitor concentration has been checked and appropriate action taken, in accordance with BS 7593 and boiler manufacturers' instructions. *					yes	n/a
Comments:						
Signature:						

*A System inhibitor efficacy test is required on every annual service in accordance with the manufacturers' instructions and BS 7593. It is only acceptable to not have undertaken this if the service engineers attendance visit was in between annual services to attend a non-water facing component.

* All installations in England and Wales must be notified to Local Authority Building Control (LABC) either directly or through a Competent Persons Scheme. A Building Regulations Compliance Certificate will then be issued to the customer.

© Heating and Hotwater Industry Council (HHIC)



www.centralheating.co.uk

SERVICE & INTERIM BOILER WORK RECORD

It is recommended that your boiler and heating system are regularly serviced and maintained, in line with manufacturers' instructions, and that the appropriate service / interim work record is completed.

Service provider

When completing a service record (as below), please ensure you have carried out the service as described in the manufacturers' instructions. Always use the manufacturers specified spare parts.

SERVICE/INTERIM WORK ON BOILER <small>delete as appropriate</small>					Date:
Engineer name:		Company name:			
Telephone N°:		Gas Safe registration N°:			
Max rate	CO	ppm	CO ₂	%	CO/CO ₂
Min rate	CO	ppm	CO ₂	%	CO/CO ₂
Where possible, has a flue integrity check been undertaken in accordance with manufacturers' instructions, and readings are correct?*					yes
Gas rate:	m ³ /h	OR	ft ³ /h		
Were parts fitted? <small>delete as appropriate</small>	Yes	No			
Parts fitted:					
System inhibitor concentration has been checked and appropriate action taken, in accordance with BS 7593 and boiler manufacturers' instructions. *					yes n/a
Comments:					
Signature:					

*A System inhibitor efficacy test is required on every annual service in accordance with the manufacturers' instructions and BS 7593. It is only acceptable to not have undertaken this if the service engineers attendance visit was in between annual services to attend a non-water facing component.

SERVICE/INTERIM WORK ON BOILER <small>delete as appropriate</small>					Date:
Engineer name:		Company name:			
Telephone N°:		Gas Safe registration N°:			
Max rate	CO	ppm	CO ₂	%	CO/CO ₂
Min rate	CO	ppm	CO ₂	%	CO/CO ₂
Where possible, has a flue integrity check been undertaken in accordance with manufacturers' instructions, and readings are correct?*					yes
Gas rate:	m ³ /h	OR	ft ³ /h		
Were parts fitted? <small>delete as appropriate</small>	Yes	No			
Parts fitted:					
System inhibitor concentration has been checked and appropriate action taken, in accordance with BS 7593 and boiler manufacturers' instructions. *					yes n/a
Comments:					
Signature:					

*A System inhibitor efficacy test is required on every annual service in accordance with the manufacturers' instructions and BS 7593. It is only acceptable to not have undertaken this if the service engineers attendance visit was in between annual services to attend a non-water facing component.

SERVICE/INTERIM WORK ON BOILER <small>delete as appropriate</small>					Date:
Engineer name:		Company name:			
Telephone N°:		Gas Safe registration N°:			
Max rate	CO	ppm	CO ₂	%	CO/CO ₂
Min rate	CO	ppm	CO ₂	%	CO/CO ₂
Where possible, has a flue integrity check been undertaken in accordance with manufacturers' instructions, and readings are correct?*					yes
Gas rate:	m ³ /h	OR	ft ³ /h		
Were parts fitted? <small>delete as appropriate</small>	Yes	No			
Parts fitted:					
System inhibitor concentration has been checked and appropriate action taken, in accordance with BS 7593 and boiler manufacturers' instructions. *					yes n/a
Comments:					
Signature:					

*A System inhibitor efficacy test is required on every annual service in accordance with the manufacturers' instructions and BS 7593. It is only acceptable to not have undertaken this if the service engineers attendance visit was in between annual services to attend a non-water facing component.

SERVICE/INTERIM WORK ON BOILER <small>delete as appropriate</small>					Date:
Engineer name:		Company name:			
Telephone N°:		Gas Safe registration N°:			
Max rate	CO	ppm	CO ₂	%	CO/CO ₂
Min rate	CO	ppm	CO ₂	%	CO/CO ₂
Where possible, has a flue integrity check been undertaken in accordance with manufacturers' instructions, and readings are correct?*					yes
Gas rate:	m ³ /h	OR	ft ³ /h		
Were parts fitted? <small>delete as appropriate</small>	Yes	No			
Parts fitted:					
System inhibitor concentration has been checked and appropriate action taken, in accordance with BS 7593 and boiler manufacturers' instructions. *					yes n/a
Comments:					
Signature:					

*A System inhibitor efficacy test is required on every annual service in accordance with the manufacturers' instructions and BS 7593. It is only acceptable to not have undertaken this if the service engineers attendance visit was in between annual services to attend a non-water facing component.

SERVICE/INTERIM WORK ON BOILER <small>delete as appropriate</small>					Date:
Engineer name:		Company name:			
Telephone N°:		Gas Safe registration N°:			
Max rate	CO	ppm	CO ₂	%	CO/CO ₂
Min rate	CO	ppm	CO ₂	%	CO/CO ₂
Where possible, has a flue integrity check been undertaken in accordance with manufacturers' instructions, and readings are correct?*					yes
Gas rate:	m ³ /h	OR	ft ³ /h		
Were parts fitted? <small>delete as appropriate</small>	Yes	No			
Parts fitted:					
System inhibitor concentration has been checked and appropriate action taken, in accordance with BS 7593 and boiler manufacturers' instructions. *					yes n/a
Comments:					
Signature:					

*A System inhibitor efficacy test is required on every annual service in accordance with the manufacturers' instructions and BS 7593. It is only acceptable to not have undertaken this if the service engineers attendance visit was in between annual services to attend a non-water facing component.

SERVICE/INTERIM WORK ON BOILER <small>delete as appropriate</small>					Date:
Engineer name:		Company name:			
Telephone N°:		Gas Safe registration N°:			
Max rate	CO	ppm	CO ₂	%	CO/CO ₂
Min rate	CO	ppm	CO ₂	%	CO/CO ₂
Where possible, has a flue integrity check been undertaken in accordance with manufacturers' instructions, and readings are correct?*					yes
Gas rate:	m ³ /h	OR	ft ³ /h		
Were parts fitted? <small>delete as appropriate</small>	Yes	No			
Parts fitted:					
System inhibitor concentration has been checked and appropriate action taken, in accordance with BS 7593 and boiler manufacturers' instructions. *					yes n/a
Comments:					
Signature:					

*A System inhibitor efficacy test is required on every annual service in accordance with the manufacturers' instructions and BS 7593. It is only acceptable to not have undertaken this if the service engineers attendance visit was in between annual services to attend a non-water facing component.

* All installations in England and Wales must be notified to Local Authority Building Control (LABC) either directly or through a Competent Persons Scheme. A Building Regulations Compliance Certificate will then be issued to the customer.

© Heating and Hotwater Industry Council (HHIC)



www.centralheating.co.uk

© Copyright

All technical and technological information contained in these technical instructions, as well as any drawings and technical descriptions supplied, remain our property and shall not be multiplied without our prior consent in writing. Subject to alterations.

Baxi Customer Support



0344 871 1545

Opening hours

Monday - Friday, 8.00am-6.00pm

Weekends and Bank Holidays, 8.30am-2.00pm

Please note calls may be recorded for training and monitoring purposes



baxi.co.uk

Register now to activate your warranty:

www.baxi.co.uk/registration

For the warranty to be maintained, please make sure...

- 1** Benchmark checklist is completed
- 2** Warranty is registered within 30 days
- 3** The boiler has an annual service

For full terms and conditions, visit www.baxi.co.uk/terms. Failure to adhere to terms and conditions will void your manufacturer's warranty.



Baxi
Brooks House,
Coventry Road,
Warwick, CV34 4LL

CE
0085



Please ensure the boiler is installed in accordance with these installation instructions and that you adhere to the Building Regulations.



e&oe

All descriptions and illustrations provided in this document have been carefully prepared but we reserve the right to make changes and improvements in our products which may affect the accuracy of the information contained in this leaflet. All goods are sold subject to our standard Conditions of Sale which are available on request.

BAXI