

E-SYSTEM ONE



The stylish E-System ONE comes with a brilliant white fascia and a host of high-end features, including the energy saving 'Auto' function and an easy to use backlit display.

- / XTRATECH™ stainless steel heat exchanger
- / 'Auto' function technology
- / Comfort function
- / High efficiency pump
- / 1:7 modulation
- / Quiet operation starting at 49dB
- / Lightweight unit starting at 29kg
- / 2 year warranty
- / 'A' ErP rated for optimum energy efficiency
- / Large backlit display
- / Includes LPG conversion kit
- / Ariston NET compatible

ENERGY RATING



XtraTech™
stainless-steel heat exchanger



PERFORMANCE
CERTIFIED BY
TÜV RHEINLAND
GROUP

www.tuv.com
ID 000096520



ARISTON NET
COMPATIBLE



SUPER
SILENT



EASY
TO USE



ITALIAN
DESIGN



SYSTEM
MANAGEMENT



AUTO
FUNCTION



EASY
INSTALLATION



EASY
MAINTENANCE

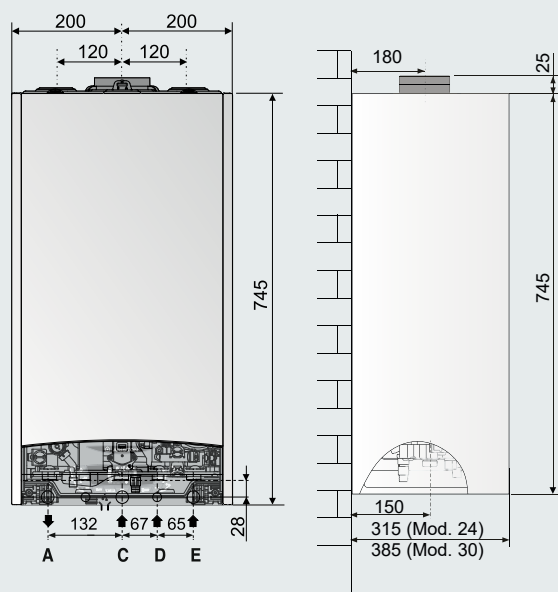

KEY

- A \ Central heating flow
- C \ Gas inlet
- D \ Domestic cold water inlet
- E \ Central heating return

TECHNICAL DATA

24

30

Efficiency

	Rating	24	30
ERP rating - heating/DHW	Rating	A	A
ERP data - seasonal space heating efficiency	%	93	94
ERP data - water heating energy efficiency	%	-	-
ERP data - noise level	dB	51	49
ERP data - tapping profile	-	-	-
SEDBUK rating	Band	A	A
SAP efficiency 2005	%	90.1	90.3
SAP efficiency 2009/2012	%	89.5	89.5

Power & Performance

		24	30
DHW flow rate ΔT @ 35°C	l/min	-	-
Heat output max (CH)	kW	22	28
Heat output max (DHW)	kW	-	-
Min/Max heating temperature (high temp. range)	°C	35/82	35/82
Min/Max heating temperature (low temp. range)	°C	20/45	20/45
DHW temperature min/max	°C	-	-

Characteristics

		24	30
Minimum ambient temperature	°C	5	5
DHW minimum flow rate	l/min	-	-
DHW pressure - min/max	bar	-	-
Built-in expansion vessel capacity	l	8	8
Servicing clearances - top/front/bottom	mm	300/450/250	300/450/250
Servicing clearances - left/right	mm	5/5	5/5
Weight	kg	29.3	31.9
NOx	mg/kWh	53	51

Electrical Data

		24	30
Electrical supply	V/Hz	230/50	230/50
Protection grade of electrical system	IP	X5D	X5D

Product Codes

3301056

3301057

E-SYSTEM ONE



Coaxial flue

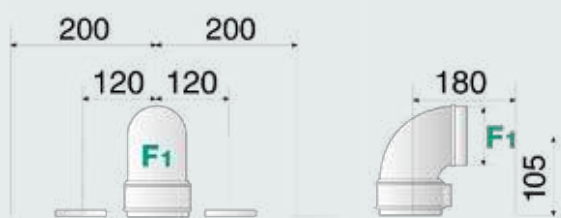

Maximum flue length:

Ø60/100: up to 8m (24) - 7m (30)
 Ø80/125: up to 33m (24) - 24m (30)

Twin flue configurations also possible

Coaxial manifold exhaust / intake

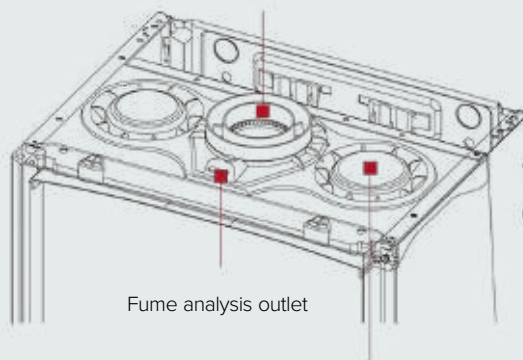

Fume analysis outlet

Air intake manifold for split exhaust systems

Hydraulic scheme

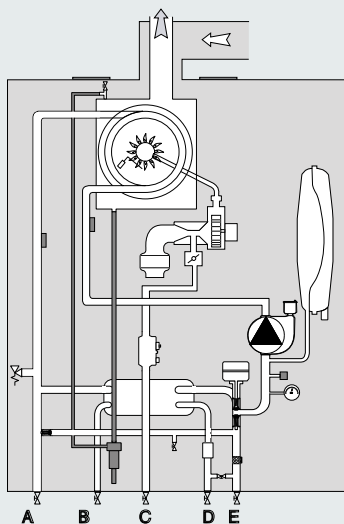

Please see installation manual for full details