

E-COMBI ONE



The stylish E-Combi ONE comes with a brilliant white fascia and a host of high-end features, including the energy saving 'Auto' function and the easy to use backlit display.

- / XTRATECH™ stainless steel heat exchanger
- / High domestic hot water flow rates
- / 'Auto' function technology
- / Comfort function
- / High efficiency pump
- / 1:7 modulation
- / Quiet operation starting at 49dB
- / Lightweight unit starting at 29kg
- / 2 year warranty
- / 'A' ErP rated for optimum energy efficiency
- / Large backlit display
- / Includes LPG conversion kit
- / Ariston NET compatible

ENERGY RATING



XtraTech™
stainless-steel heat exchanger



PERFORMANCE
CERTIFIED BY
TUV RHEINLAND
GROUP

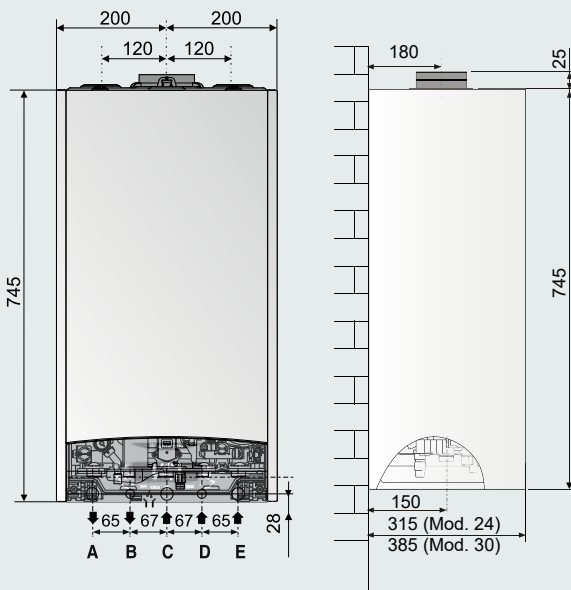

KEY

- A \ Central heating flow
- B \ Domestic hot water outlet
- C \ Gas inlet
- D \ Domestic hot water inlet
- E \ Central heating return

TECHNICAL DATA

24

30

Efficiency

	Rating	24	30
ERP rating - heating/DHW	Rating	A/A	A/A
ERP data - seasonal space heating efficiency	%	94	94
ERP data - water heating energy efficiency	%	83	82
ERP data - noise level	dB	49	51
ERP data - tapping profile	-	XL	XL
SEDBUK rating	Band	A	A
SAP efficiency 2005	%	90	90.2
SAP efficiency 2009/2012	%	89.4	89.4

Power & Performance

		24	30
DHW flow rate ΔT @ 35°C	l/min	10.4	12.5
Heat output max (CH)	kW	22	28
Heat output max (DHW)	kW	26	30
Min/Max heating temperature (high temp. range)	°C	35/82	35/82
Min/Max heating temperature (low temp. range)	°C	20/45	20/45
DHW temperature min/max	°C	36/60	36/60

Characteristics

		24	30
Minimum ambient temperature	°C	5	5
DHW minimum flow rate	l/min	2	2
DHW pressure - min/max	bar	0.2/7	0.2/7
Built-in expansion vessel capacity	l	8	8
Servicing clearances - top/front/bottom	mm	300/450/250	300/450/250
Servicing clearances - left/right	mm	5/5	5/5
Weight	kg	29.3	31.9
NOx	mg/kWh	53	51

Electrical Data

		24	30
Electrical supply	V/Hz	230/50	230/50
Protection grade of electrical system	IP	X5D	X5D

Product Codes

3301131

3301132

E-COMBI ONE



Coaxial flue

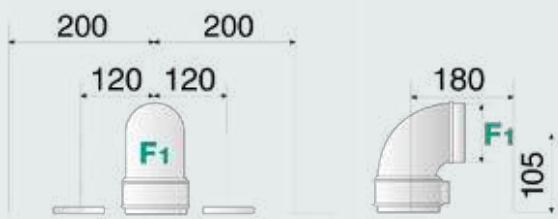

Maximum flue length:

Ø60/100: up to 8m (24) - 7m (30)
 Ø80/125: up to 33m (24) - 24m (30)

Twin flue configurations also possible

Coaxial manifold exhaust / intake

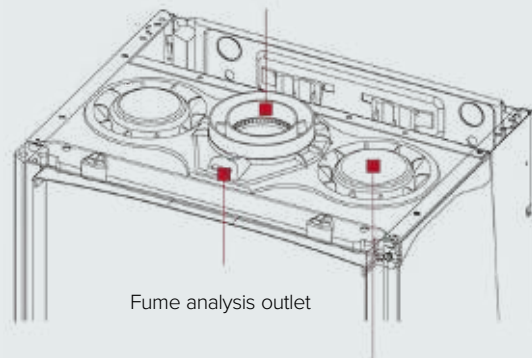

Fume analysis outlet

Air intake manifold for split exhaust systems

Hydraulic scheme

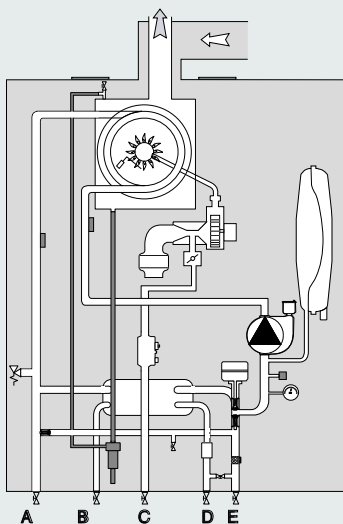

Please see installation manual for full details



**HOME GETS SMARTER,
LIFE GETS SIMPLER**

**ENJOY ARISTON NET
CONNECTIVITY**

**COMFORT AT YOUR
FINGERTIPS WITH THE
ARISTON NET APP**

